

North Carolina Department of Natural and Cultural Resources
State Historic Preservation Office

Ramona M. Bartos, Administrator

Governor Roy Cooper
Secretary Susi H. Hamilton

Office of Archives and History
Deputy Secretary Kevin Cherry

October 8, 2019

Angela McGill
High Point Housing Authority
500 East Russell Avenue
High Point, NC 27261

amcgill@hpha.net

Re: Daniel Brooks Public Housing Redevelopment, West Avenue and Henly Street, High Point,
Guilford County, ER 17-1736

Dear Ms. McGill:

Thank you for your letter of September 6, 2019, transmitting the printed and digital copies of the Daniel Brooks Public Housing complex recordation packet/documentation report. We approve of the materials as presented and consider them sufficient for compliance with Stipulation I of the MOA. We require no further documentation of the Daniel Brooks complex. The submitted documentation will be archived with the historic property's survey site file.

We look forward to receiving news that the historic plaque and new commemorative exhibit have been installed within the new complex. Should you have any questions during the development of the exhibit, please do not hesitate to contact us.

The above comments are made pursuant to Section 106 of the National Historic Preservation Act and the Advisory Council on Historic Preservation's Regulations for Compliance with Section 106 codified at 36 CFR Part 800.

Thank you for your cooperation and consideration. If you have questions concerning the above comment, contact Renee Gledhill-Earley, environmental review coordinator, at 919-814-6579 or environmental.review@ncdcr.gov. In all future communication concerning this project, please cite the above referenced tracking number.

Sincerely,

for Ramona Bartos, Deputy
Deputy State Historic Preservation Officer

cc: Eugene Rahuba, DHUD, Eugene.A.Rahuba@hud.gov



Development: Daniel Brooks Homes
Building Number: NA
Description: Neighborhood Entrance Sign
Photographer: High Point Housing Authority
Date Taken: June 14, 2019
Digital Photo: Daniel Brooks Entrance



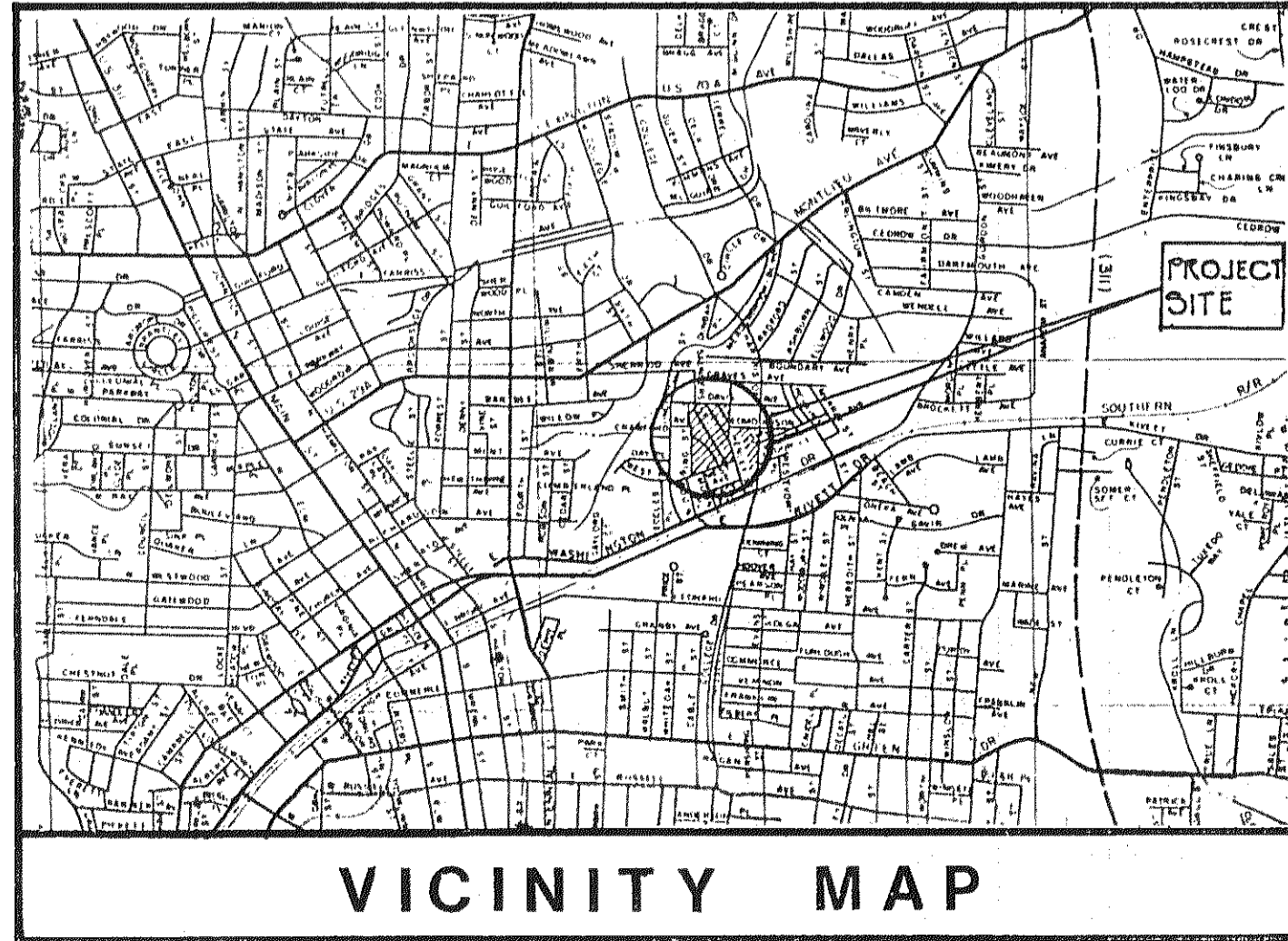

LETTER INDICATES BUILDING TYPE
 NO. INDICATES BUILDING NO.
 SMALL NO. INDICATES LIVING UNIT NO.

NOTE:
 NO WORK REQUIRED FOR BUILDINGS
 323, 1419, 1421, 1423, 1427, 1431, 1453,
 1455, 1469 & 1471 AND SHOWN SHADED.

PROJECT SITE PLAN

1" = 50'

PHASE 2 CONSTRUCTION
 MODERNIZATION OF DANIEL BROOKS HOMES NC 5-2
 PROJECT CIAP NC 6-905
 FOR HOUSING AUTHORITY OF THE CITY OF HIGH POINT

CONTENTS:
 PROJECT SITE PLAN

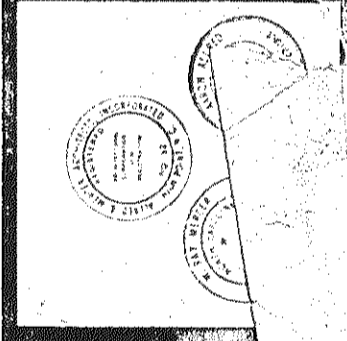

ALLRED & MERCER ARCHITECTS, INC.
 ARCHITECTS
 100 THE AMERICAN FISH MARKET
 HIGH POINT, N.C. 27262

COM
 DAY



Development: Daniel Brooks Homes
Building Number: 1443 West Ave.
Description: Street View of the 1400 Block of West Ave.
Photographer: High Point Housing Authority
Date Taken: June 14, 2019
Digital Photo: 1443 West Street View



Development: Daniel Brooks Homes

Building Number: 1479 West Ave.

Description: Yard View of the 1400 Block of West Ave.

Photographer: High Point Housing Authority

Date Taken: June 14, 2019

Digital Photo: 1479 West Green Space

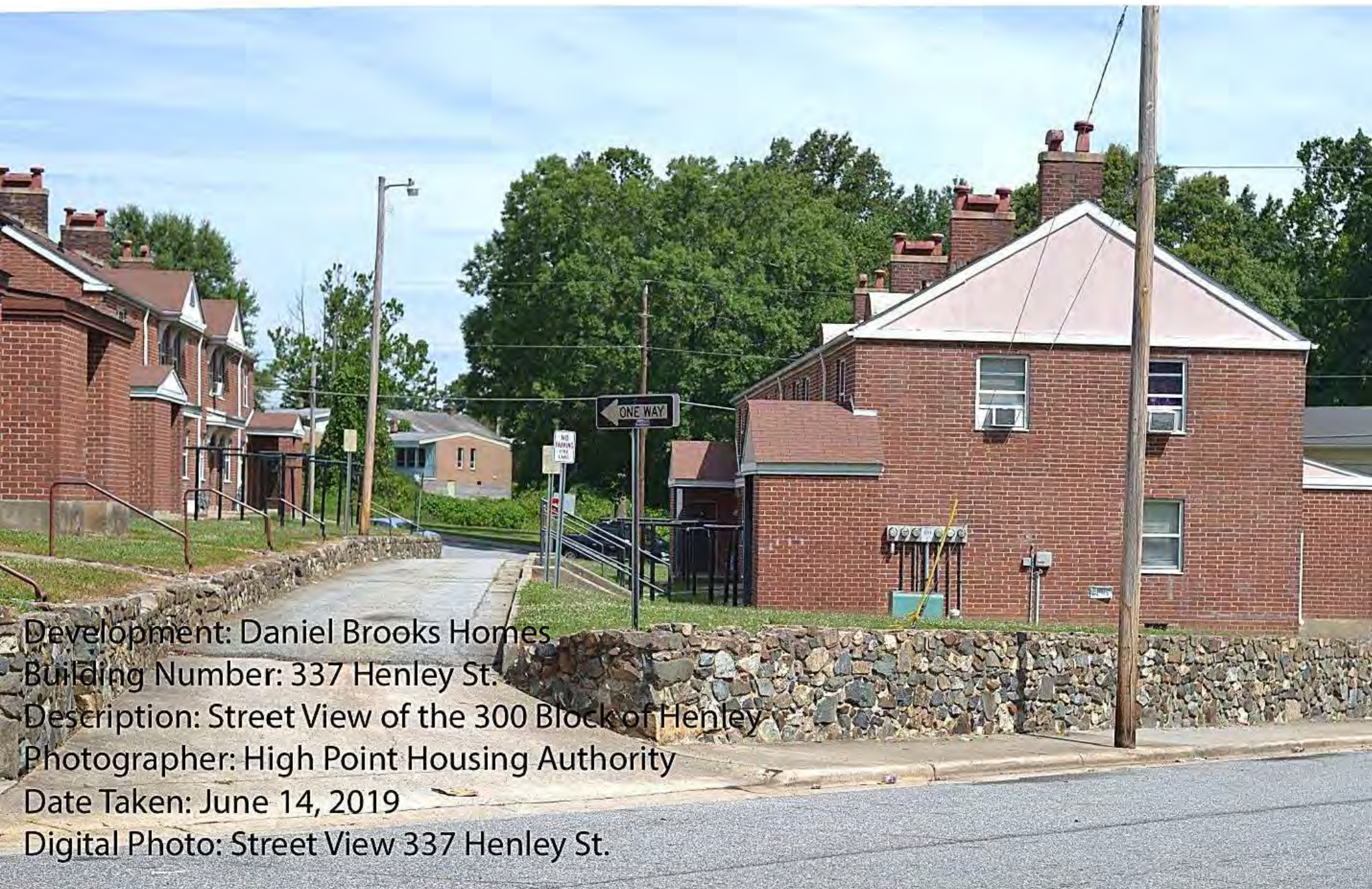

Development: Daniel Brooks Homes

Building Number: 337 Henley St.

Description: Street View of the 300 Block of Henley

Photographer: High Point Housing Authority

Date Taken: June 14, 2019

Digital Photo: Street View 337 Henley St.

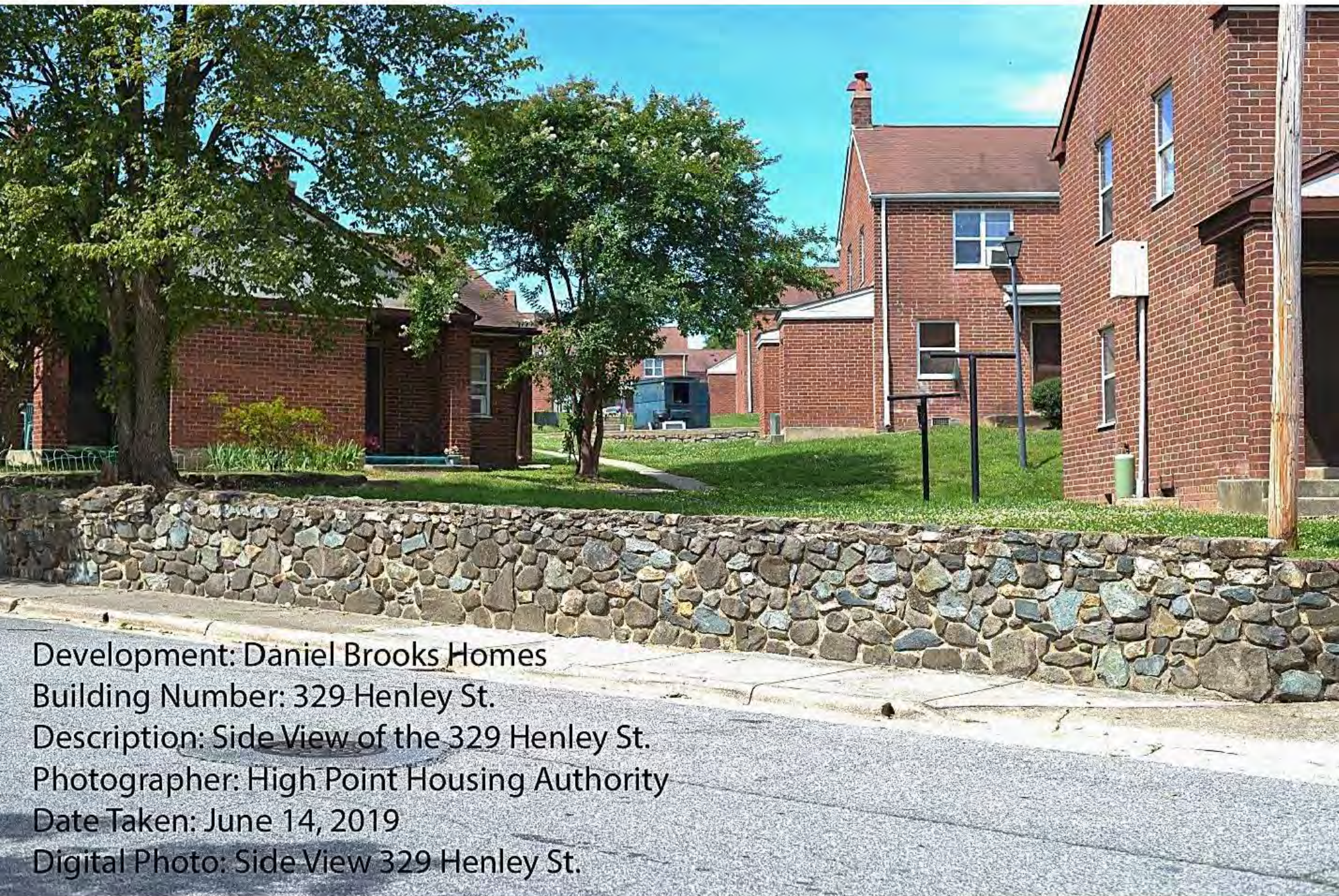

Development: Daniel Brooks Homes

Building Number: 329 Henley St.

Description: Side View of the 329 Henley St.

Photographer: High Point Housing Authority

Date Taken: June 14, 2019

Digital Photo: Side View 329 Henley St.



Development: Daniel Brooks Homes

Building Number: 1447 West Ave.

Description: Yard View 1447 West Ave.

Photographer: High Point Housing Authority

Date Taken: June 14, 2019

Digital Photo: Green Space 1447 West Ave.

Daniel Brooks
Early Head Start Center



1453 West Ave.
886-7732

GuilfordChildDevelopment

Development: Daniel Brooks Homes
Building Number: 1453 West Ave.
Description: Daniel Brooks Day Care Sign
Photographer: High Point Housing Authority
Date Taken: June 14, 2019
Digital Photo: Day Care Sign



Development: Daniel Brooks Homes
Building Number: 1453 West Ave.
Description: Yard View Daniel Brooks Day Care
Photographer: High Point Housing Authority
Date Taken: June 14, 2019
Digital Photo: Day Care Yard View



Development: Daniel Brooks Homes
Building Number: 1453 West Ave.
Description: Front View Daniel Brooks Day Care
Photographer: High Point Housing Authority
Date Taken: June 14, 2019
Digital Photo: Day Care Front View



Development: Daniel Brooks Homes
Building Number: 1455 West Ave.
Description: Daniel Brooks Community Center
Photographer: High Point Housing Authority
Date Taken: June 14, 2019
Digital Photo: Daniel Brooks Community Center Interior



Development: Daniel Brooks Homes
Building Number: 319 Henley Ave.
Description: Yard View Near 319 Henley Ave.
Photographer: High Point Housing Authority
Date Taken: June 14, 2019
Digital Photo: 319 Henley Ave. Front View



Development: Daniel Brooks Homes

Building Number: 327 Henley St.

Description: Street View of the 327 Henley St.

Photographer: High Point Housing Authority

Date Taken: June 14, 2019

Digital Photo: Street View 327 Henley St.

DANIEL BROOKS HOMES
BUILT BY
HOUSING AUTHORITY OF THE CITY OF
HIGH POINT, NORTH CAROLINA
WITH THE ASSISTANCE OF
THE UNITED STATES HOUSING AUTHORITY
FRANKLIN D. ROOSEVELT
PRESIDENT OF THE UNITED STATES OF AMERICA
JOHN M. CARMODY **NATHAN STRAUS**
ADMINISTRATOR OF THE ADMINISTRATOR OF THE
FEDERAL WORKS AGENCY U.S. HOUSING AUTHORITY
WITH THE COOPERATION OF THE
CITY OF HIGH POINT
O. ARTAUR S. IRKMAN
MAYOR
HOUSING AUTHORITY OF THE
CITY OF HIGH POINT
CHAIRMAN CURTIS
VICE CHAIRMAN W. H. HANCOCK
MEMBERS J. H. BOWEN
REPRESENTATIVE W. L. LINDSEY
COUNCILOR
J. E. D. COX EXECUTIVE DIRECTOR
ARCHITECT LANDSCAPE ARCHITECT
TYSON T. FERREE **W. D. TILLSON**
CONTRACTOR
P. G. WEST CONSTRUCTION CO., INC.
1941

Development: Daniel Brooks Homes

Building Number: 1455 West Ave.

Description: Daniel Brooks Community Plaque

Photographer: High Point Housing Authority

Date Taken: June 14, 2019

Digital Photo: Daniel Brooks Community Plaque



Development: Daniel Brooks Homes
Building Number: 1455 West Ave
Description: Daniel Brooks Honorary Flagpole
Photographer: High Point Housing Authority
Date Taken: June 14, 2019
Digital Photo: Daniel Brooks Honorary Flagpole



Development: Daniel Brooks Homes
Building Number: NA
Description: Intricate Stone Retainer Walls
Photographer: High Point Housing Authority
Date Taken: June 14, 2019
Digital Photo: Intricate Stone Retainer Walls 1



Development: Daniel Brooks Homes

Building Number: NA

Description: Intricate Stone Retainer Walls

Photographer: High Point Housing Authority

Date Taken: June 14, 2019

Digital Photo: Intricate Stone Retainer Walls 2

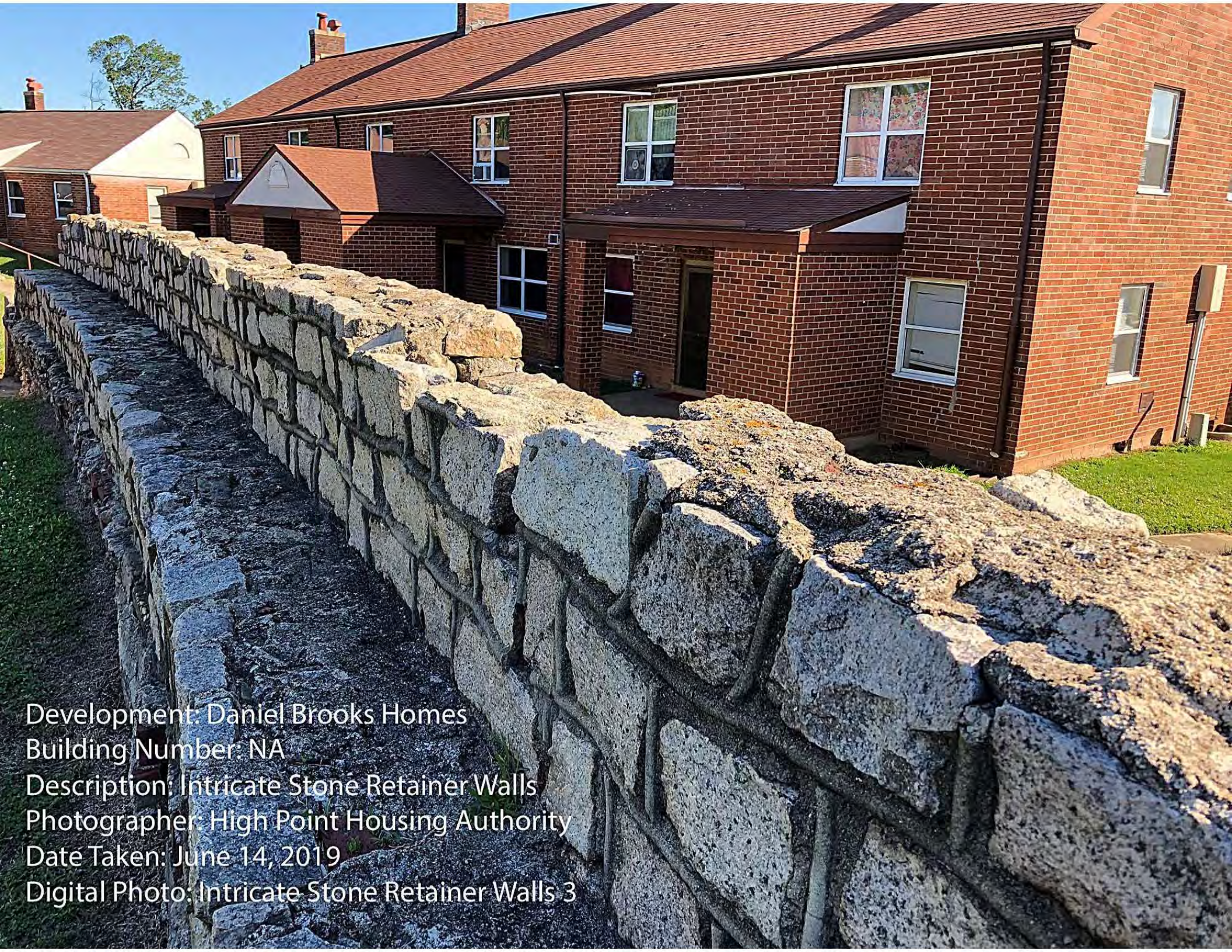

Development: Daniel Brooks Homes
Building Number: NA
Description: Intricate Stone Retainer Walls
Photographer: High Point Housing Authority
Date Taken: June 14, 2019
Digital Photo: Intricate Stone Retainer Walls 3



Development: Daniel Brooks Homes
Building Number: NA
Description: Intricate Stone Retainer Walls
Photographer: High Point Housing Authority
Date Taken: June 14, 2019
Digital Photo: Intricate Stone Retainer Walls 4

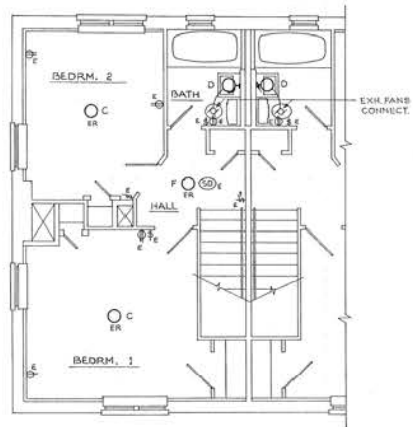

BLOG. A SECOND FLOOR PLAN

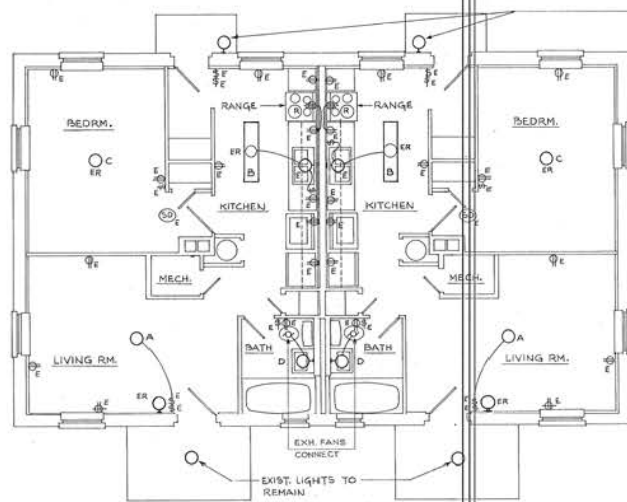

BLOG. B FLOOR PLAN

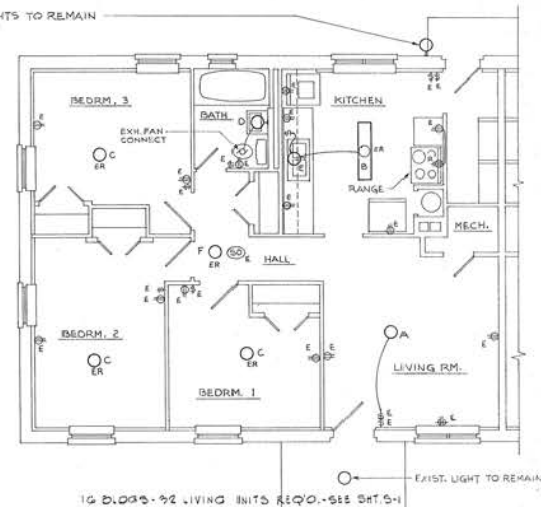

BLOG. C FLOOR PLAN

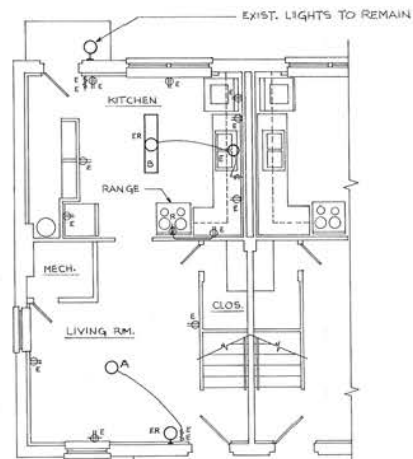

13 BLDGS. - 18 LIVING UNITS REQD. - SEE SHT. 5-1

BLOG. A FIRST FLOOR PLAN

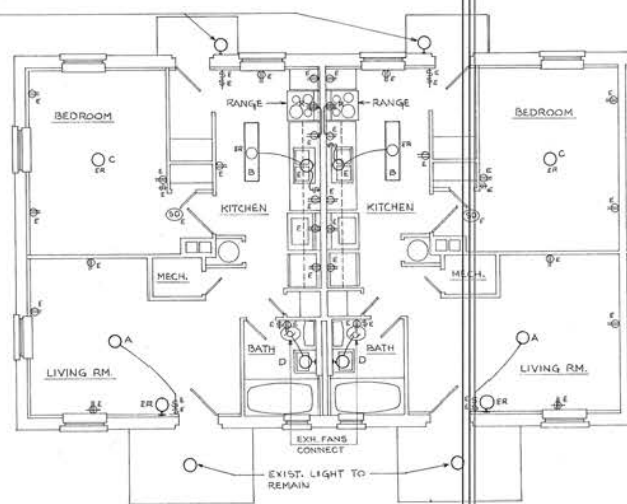

5 BLDGS. - 30 LIVING UNITS REQD. - SEE SHT. 5-1

BLOG. D FLOOR PLAN

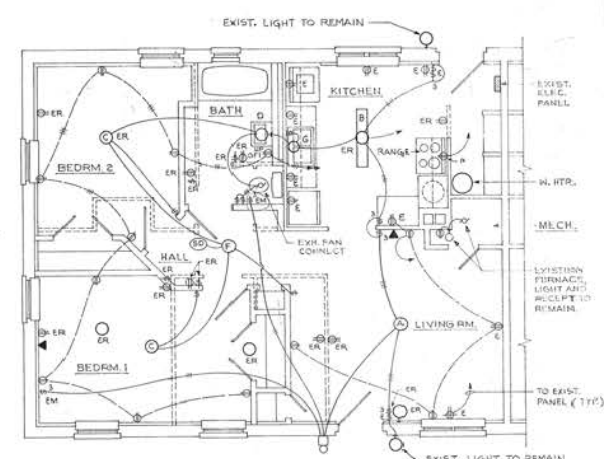

4 BLDGS. - 8 LIVING UNITS REQUIRED - SEE SHT. 5-1

BUILDING H FLOOR PLAN

PHASE 2 CONSTRUCTION
 MODERNIZATION OF DANIEL BROOKS HOMES - MC 9-2
 PROJECT C/P A/P NC 6-0-05
 HOUSING AUTHORITY OF THE CITY OF HIGH POINT

CONTENTS
 ELECTRICAL
 FLOOR PLANS

ALLRED & HERCER, ARCHITECTS, INC.

MEMBER OF THE AMERICAN INSTITUTE OF ARCHITECTS
 THE FLOOR LEVEL - HIGH POINT, N. C. 27262 - TELEPHONE 883-9223

CONTRACT NO. 34
 DATE: 5/11/64
 SHEET NO.
 F-1
 OF 2 SHEETS



Development: Daniel Brooks Homes
Building Number: 1459 West Ave.
Description: Unit Type A
Photographer: High Point Housing Authority
Date Taken: June 14, 2019
Digital Photo: 1459 West Ave. Unit Type A1



Development: Daniel Brooks Homes
Building Number: 1459 West Ave.
Description: Unit Type A
Photographer: High Point Housing Authority
Date Taken: June 14, 2019
Digital Photo: 1459 West Ave. Unit Type A2



Development: Daniel Brooks Homes
Building Number: 1459 West Ave.
Description: Unit Type A
Photographer: High Point Housing Authority
Date Taken: June 14, 2019
Digital Photo: 1459 West Ave. Unit Type A3



Development: Daniel Brooks Homes
Building Number: 1459 West Ave.
Description: Unit Type A
Photographer: High Point Housing Authority
Date Taken: June 14, 2019
Digital Photo: 1459 West Ave. Unit Type A4

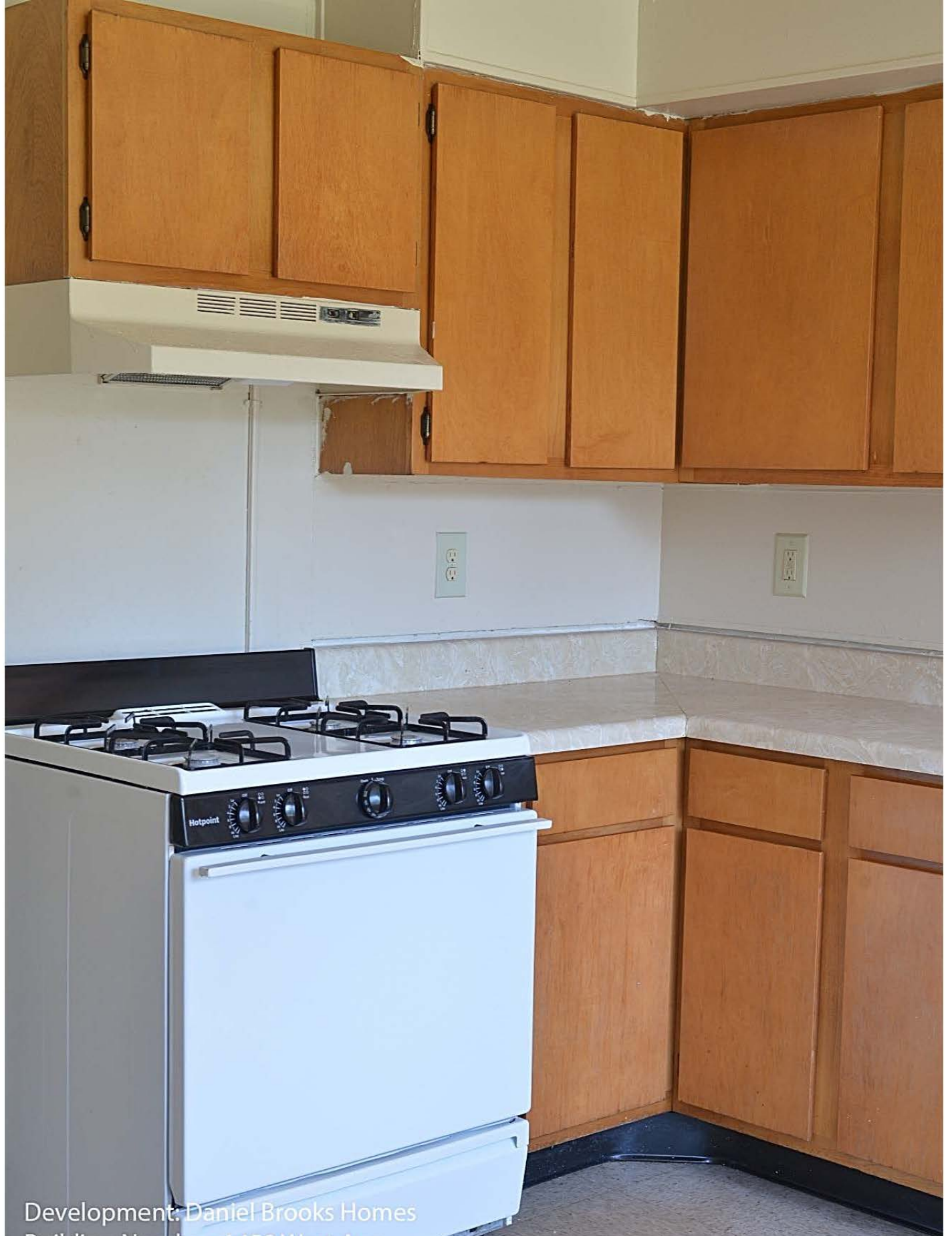

Development: Daniel Brooks Homes
Building Number: 1459 West Ave.
Description: Unit Type A
Photographer: High Point Housing Authority
Date Taken: June 14, 2019
Digital Photo: 1459 West Ave. Unit Type A5

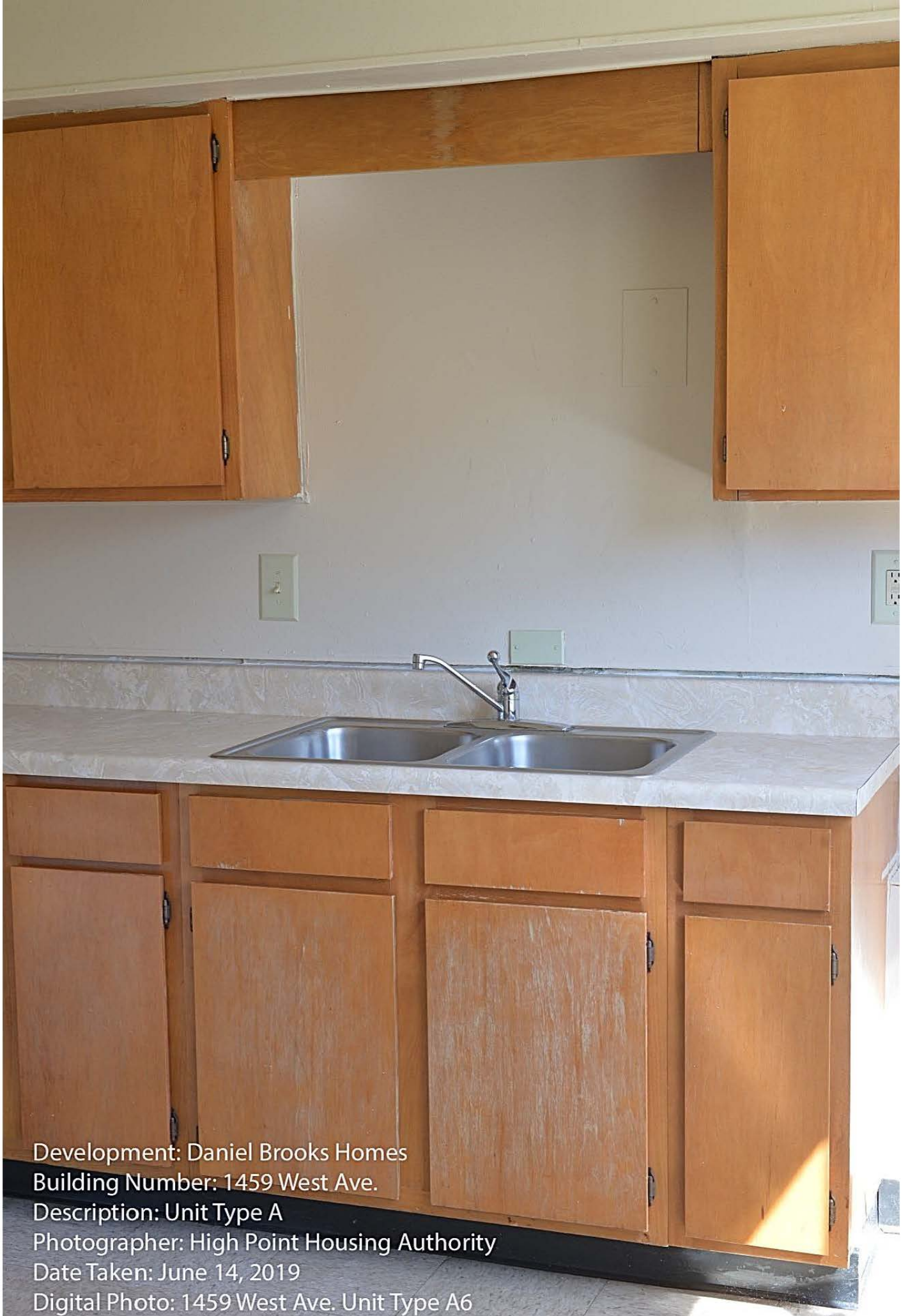

Development: Daniel Brooks Homes
Building Number: 1459 West Ave.
Description: Unit Type A
Photographer: High Point Housing Authority
Date Taken: June 14, 2019
Digital Photo: 1459 West Ave. Unit Type A6



Development: Brookdale Homes
Building Number: 329-B Henley St
Description: Unit Type B
Photographer: High Point Housing Authority
Date Taken: June 14, 2019
Digital Photo: 329-B Henley St: Unit Type B1



Development: Daniel Brooks Homes
Building Number: 329-B Henley St.
Description: Unit Type B
Photographer: High Point Housing Authority
Date Taken: June 14, 2019
Digital Photo: 329-B Henley St. Unit Type B2



Development: Daniel Brooks Homes
Building Number: 329-B Henley St.
Description: Unit Type B3
Photographer: High Point Housing Authority
Date Taken: June 14, 2019
Digital Photo: 329-B Henley St. Unit Type B3

The image shows a kitchen area with a white four-burner gas stove in the foreground. To the right of the stove is a window with a white frame, showing a white vehicle parked outside. In the background, a doorway leads to an outdoor area with trees and a utility pole. The wall is white and has a light switch and a small hole near the baseboard. The floor is dark.

Development: Daniel Brooks Homes
Building Number: 329-B Henley St.
Description: Unit Type B
Photographer: High Point Housing Authority
Date Taken: June 14, 2019
Digital Photo: 329-B Henley St. Unit Type B4



Development: Daniel Brooks Homes
Building Number: 329-B Henley St.
Description: Unit Type B
Photographer: High Point Housing Authority
Date Taken: June 14, 2019
Digital Photo: 329-B Henley St. Unit Type B5

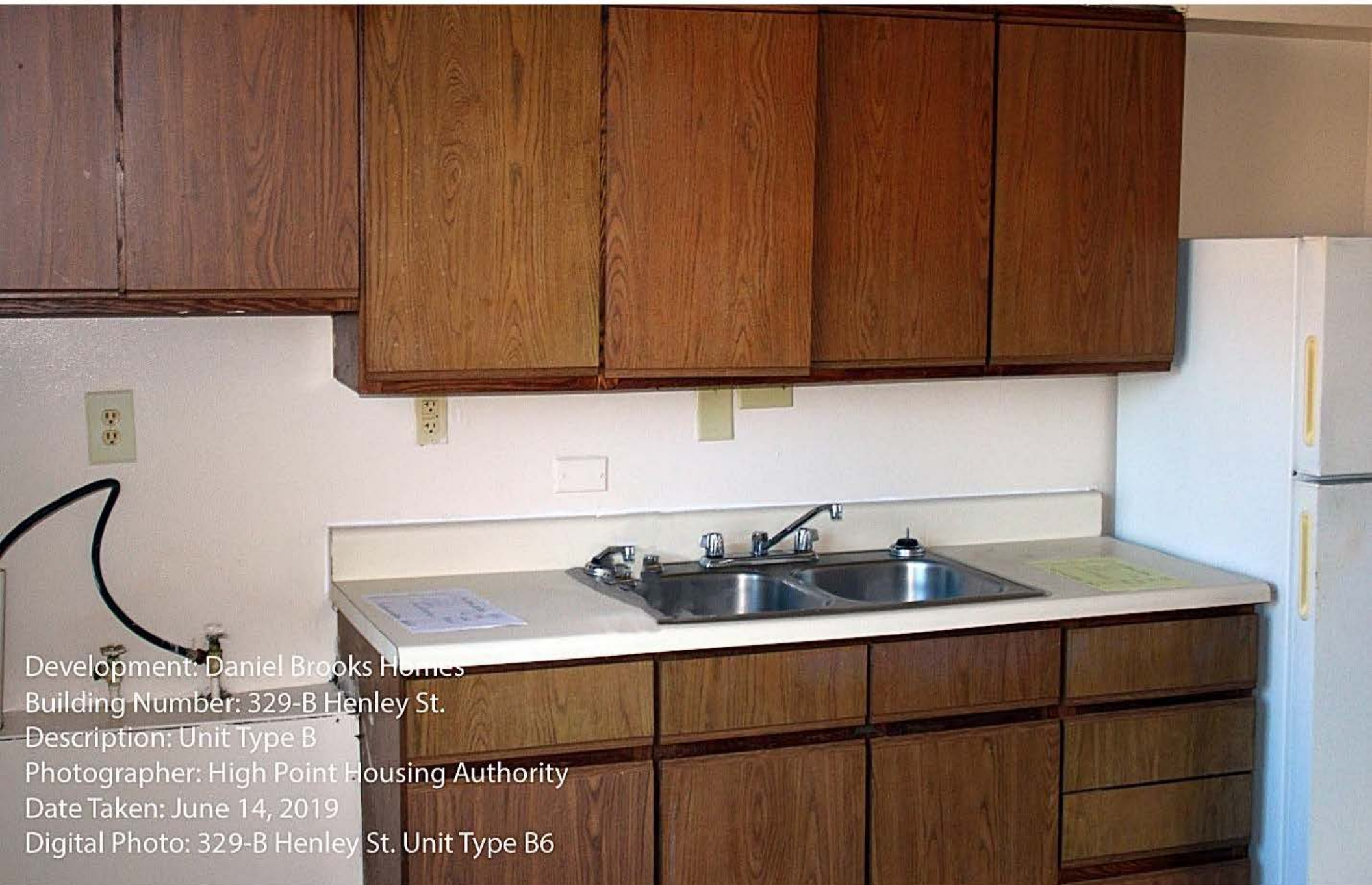

Development: Daniel Brooks Homes
Building Number: 329-B Henley St.
Description: Unit Type B
Photographer: High Point Housing Authority
Date Taken: June 14, 2019
Digital Photo: 329-B Henley St. Unit Type B6



Development: Daniel Brooks Homes
Building Number: 329-B Henley St.
Description: Unit Type B
Photographer: High Point Housing Authority
Date Taken: June 14, 2019
Digital Photo: 329-B Henley St. Unit Type B11



Development: Daniel Brooks Homes
Building Number: 329-B Henley St.
Description: Unit Type B
Photographer: High Point Housing Authority
Date Taken: June 14, 2019
Digital Photo: 329-B Henley St. Unit Type B8

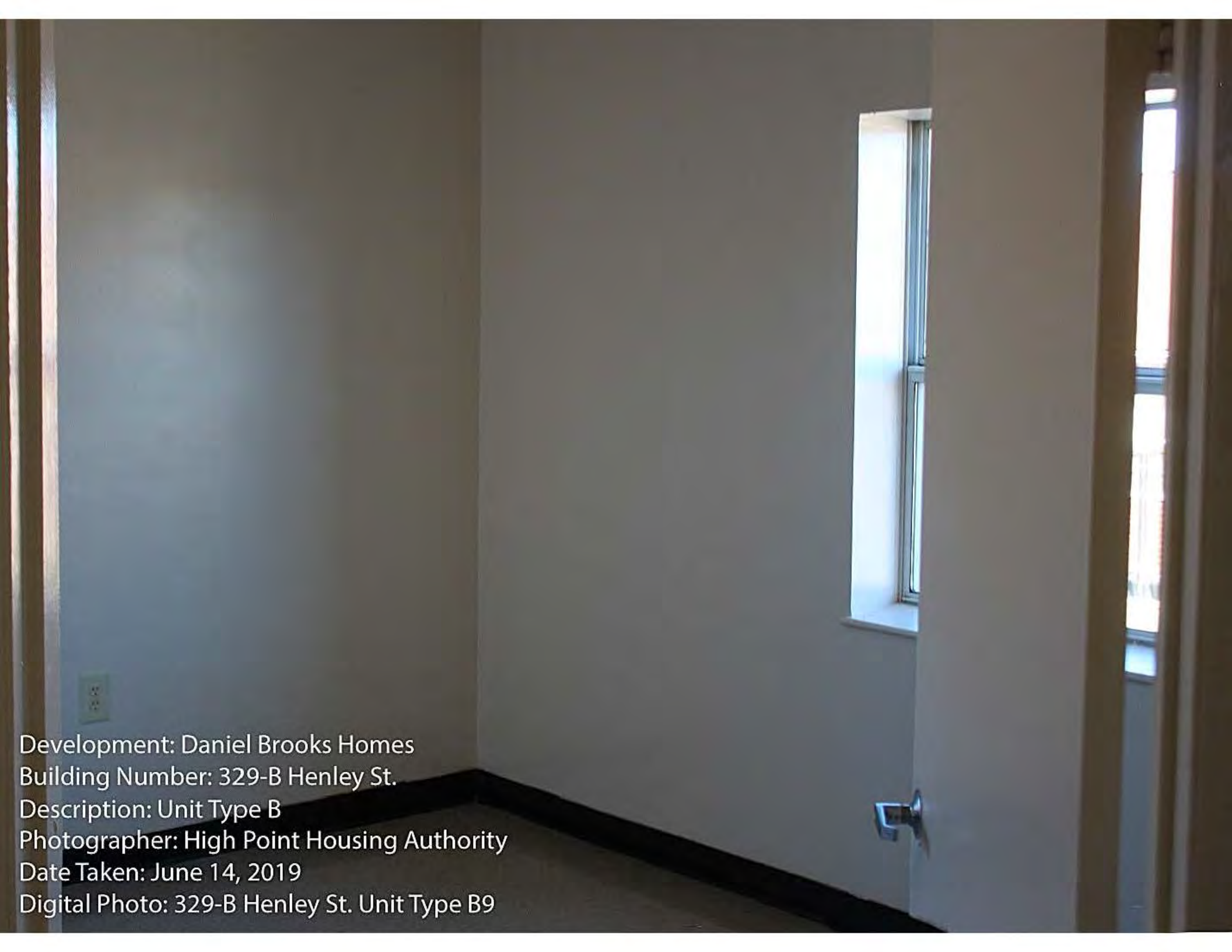

Development: Daniel Brooks Homes
Building Number: 329-B Henley St.
Description: Unit Type B
Photographer: High Point Housing Authority
Date Taken: June 14, 2019
Digital Photo: 329-B Henley St. Unit Type B9



Development: Daniel Brooks Homes
Building Number: 329-B Henley St.
Description: Unit Type B
Photographer: High Point Housing Authority
Date Taken: June 14, 2019
Digital Photo: 329-B Henley St. Unit Type B10



Development: Daniel Brooks Homes
Building Number: 329-B Henley St.
Description: Unit Type B
Photographer: High Point Housing Authority
Date Taken: June 14, 2019
Digital Photo: 329-B Henley St. Unit Type B12



Development: Daniel Brooks Homes
Building Number: 1413 West Ave.
Description: Unit Type C
Photographer: High Point Housing Authority
Date Taken: June 14, 2019
Digital Photo: 1413 West Ave. Unit Type C1



Development: Daniel Brooks Homes
Building Number: 1413 West Ave.
Description: Unit Type C
Photographer: High Point Housing Authority
Date Taken: June 14, 2019
Digital Photo: 1413 West Ave. Unit Type C2



Development: Daniel Brooks Homes
Building Number: 1413 West Ave.
Description: Unit Type C
Photographer: High Point Housing Authority
Date Taken: June 14, 2019
Digital Photo: 1413 West Ave. Unit Type C3



Development: Daniel Brooks Homes
Building Number: 1413 West Ave.
Description: Unit Type C
Photographer: High Point Housing Authority
Date Taken: June 14, 2019
Digital Photo: 1413 West Ave. Unit Type C4



Development: Daniel Brooks Homes
Building Number: 1429 West Ave.
Description: Unit Type H
Photographer: High Point Housing Authority
Date Taken: June 14, 2019
Digital Photo: 1429 West Ave. Unit Type H1



Development: Daniel Brooks Homes
Building Number: 1429 West Ave.
Description: Unit Type H
Photographer: High Point Housing Authority
Date Taken: June 14, 2019
Digital Photo: 1429 West Ave. Unit Type H2



Development: Daniel Brooks Homes

Building Number: 1429 West Ave.

Description: Unit Type H

Photographer: High Point Housing Authority

Date Taken: June 14, 2019

Digital Photo: 1429 West Ave. Unit Type H3



Development: Daniel Brooks Homes
Building Number: 1429 West Ave.
Description: Unit Type H
Photographer: High Point Housing Authority
Date Taken: June 14, 2019
Digital Photo: 1429 West Ave. Unit Type H4

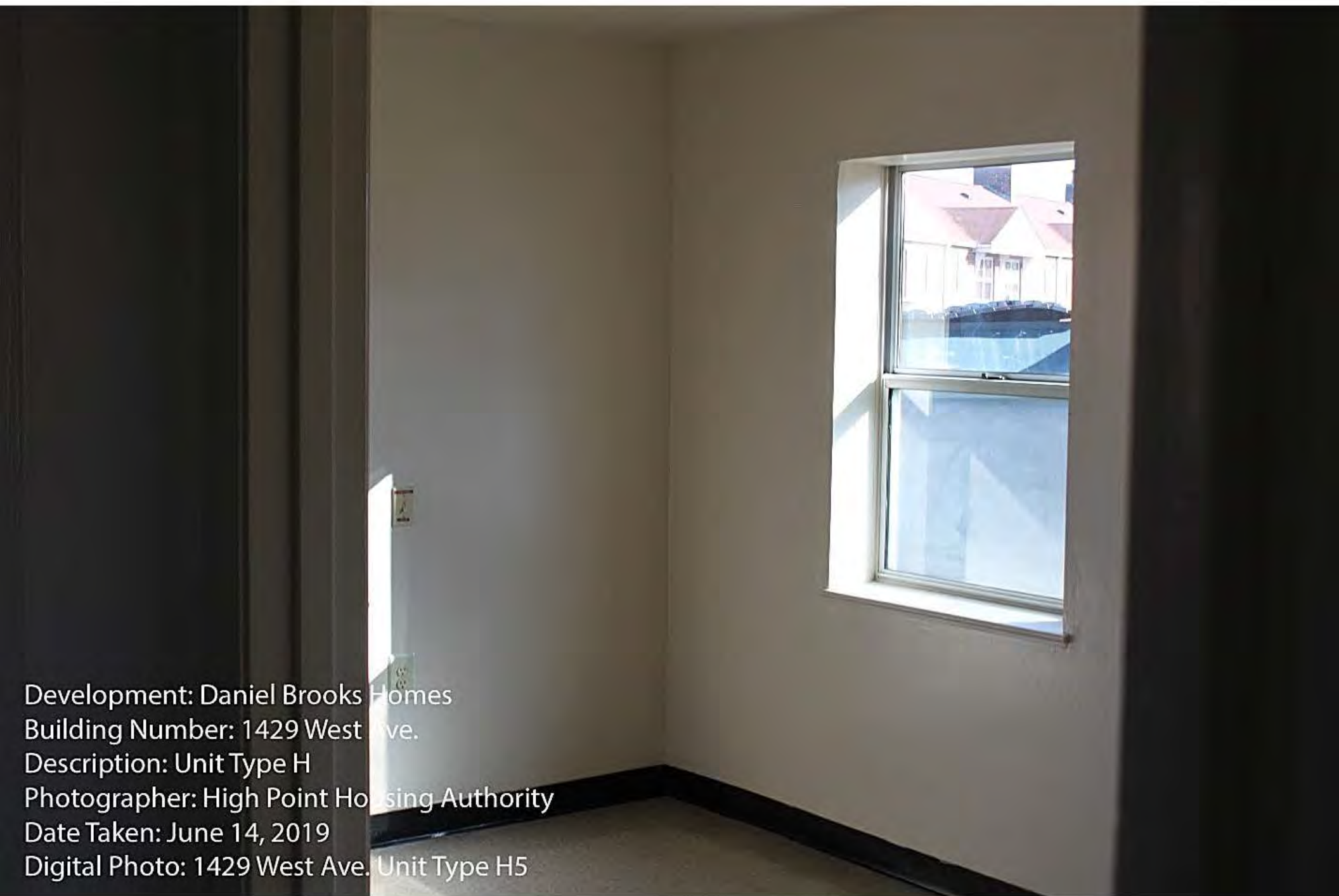

Development: Daniel Brooks Homes
Building Number: 1429 West Ave.
Description: Unit Type H
Photographer: High Point Housing Authority
Date Taken: June 14, 2019
Digital Photo: 1429 West Ave. Unit Type H5



Development: Daniel Brooks Homes

Building Number: 1429 West Ave.

Description: Unit Type H

Photographer: High Point Housing Authority

Date Taken: June 14, 2019

Digital Photo: 1429 West Ave. Unit Type H



Development: Daniel Brooks Homes
Building Number: 1429 West Ave.
Description: Unit Type H
Photographer: High Point Housing Authority
Date Taken: June 14, 2019
Digital Photo: 1429 West Ave. Unit Type H7



Development: Daniel Brooks Homes
Building Number: 1429 West Ave
Description: Unit Type H
Photographer: High Point Housing Authority
Date Taken: June 14, 2019
Digital Photo: 1429 West Ave. Unit Type H8

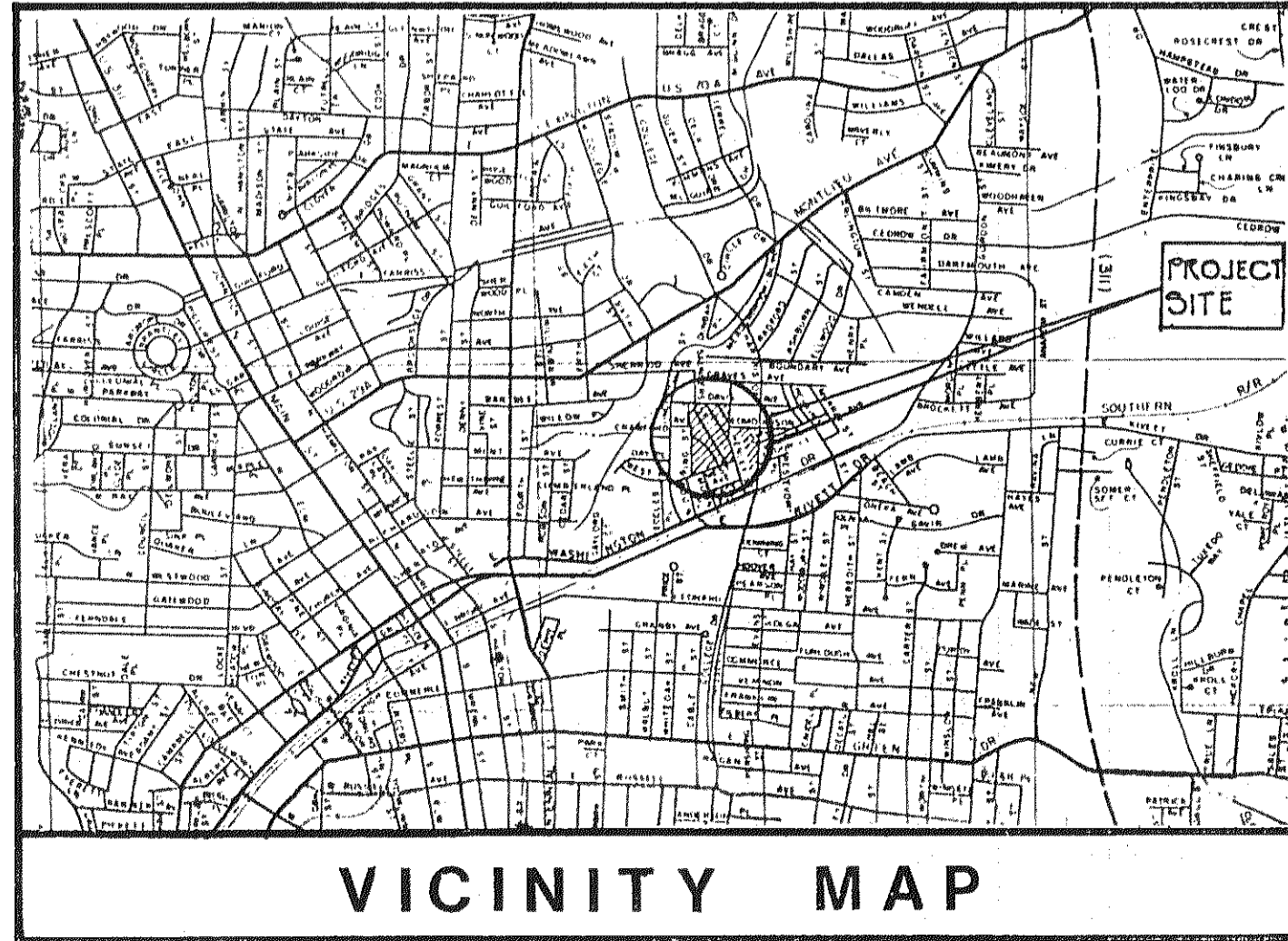

LETTER INDICATES BUILDING TYPE
 NO. INDICATES BUILDING NO.
 SMALL NO. INDICATES LIVING UNIT NO.

CONTRACTOR'S OFFICE AND STORAGE AREA

NOTE:
 NO WORK REQUIRED FOR BUILDINGS 323, 1419, 1421, 1423, 1427, 1431, 1453, 1455, 1469 & 1471 AND SHOWN SHADED.

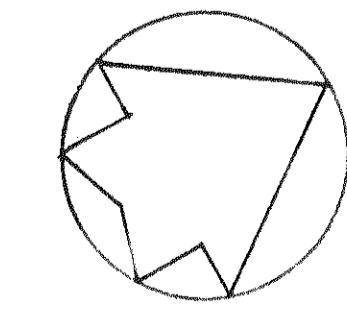

PROJECT SITE PLAN

1" = 50'

PHASE 2 CONSTRUCTION
 MODERNIZATION OF DANIEL BROOKS HOMES NC 5-2
 PROJECT CIAP NC 6-905
 FOR HOUSING AUTHORITY OF THE CITY OF HIGH POINT

CONTENTS:
 PROJECT SITE PLAN

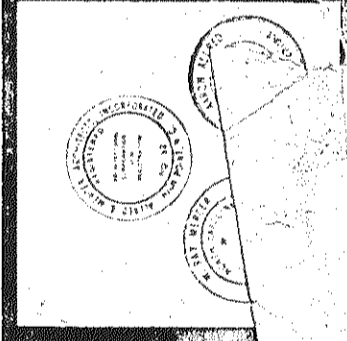

ALLRED & MERCER ARCHITECTS, INC.
 ARCHITECTS
 100 THE AMERICAN FISH MARKET
 HIGH POINT, N.C. 27262

COM
 DAY

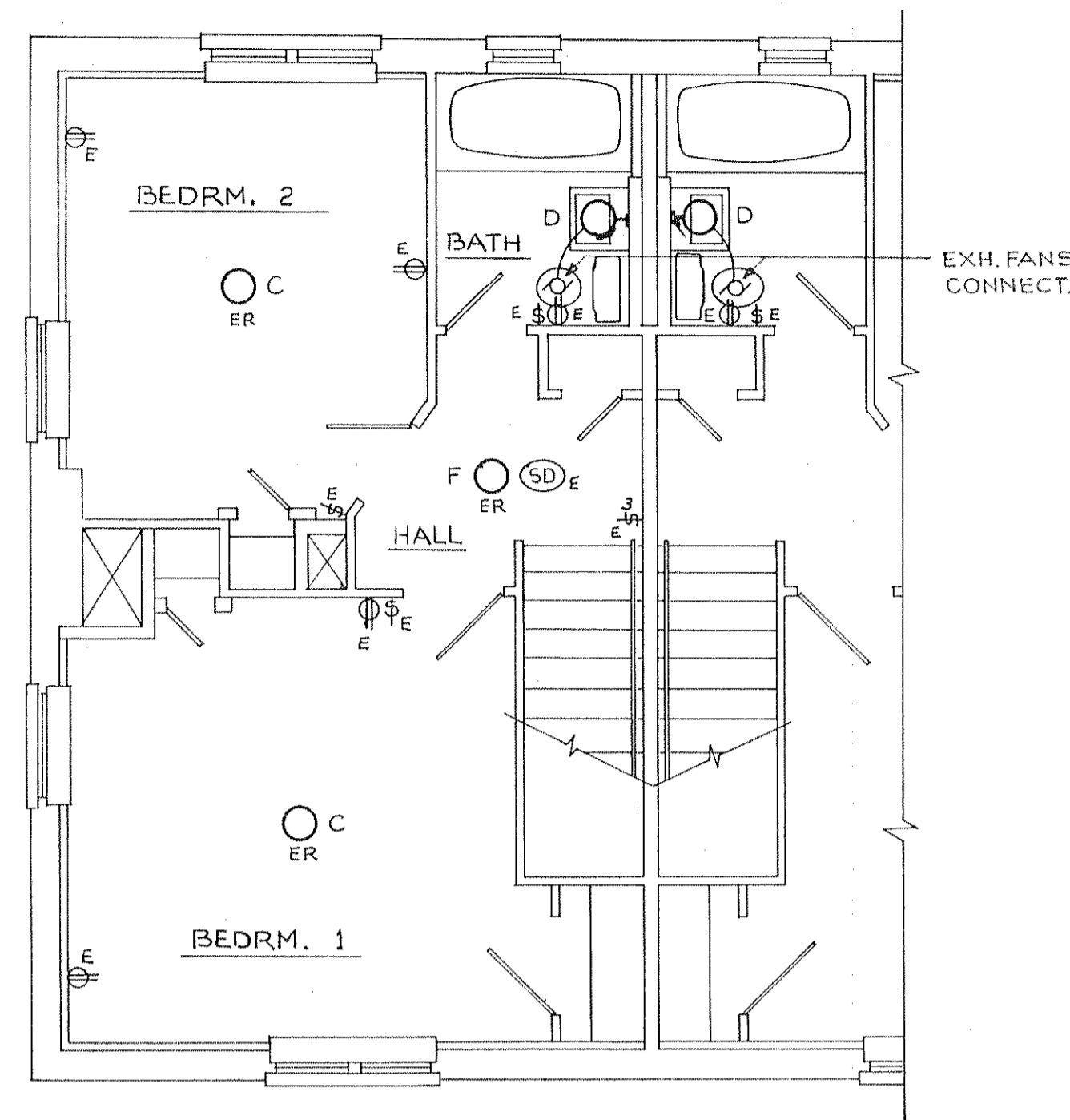

BLOG. "A" SECOND FLOOR PLAN

1/4" = 1'-0"

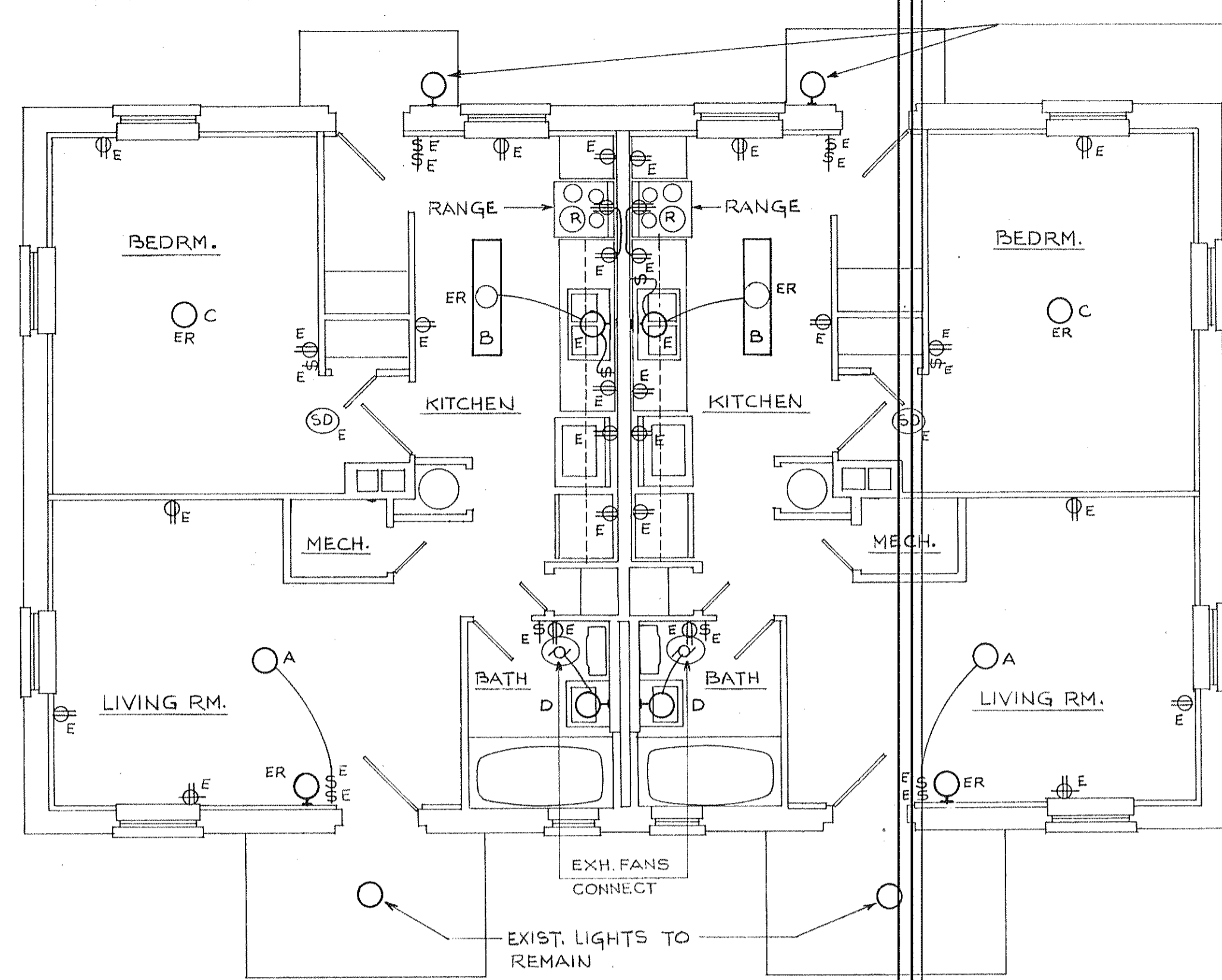

BLOG. "B" FLOOR PLAN

1/4" = 1'-0"

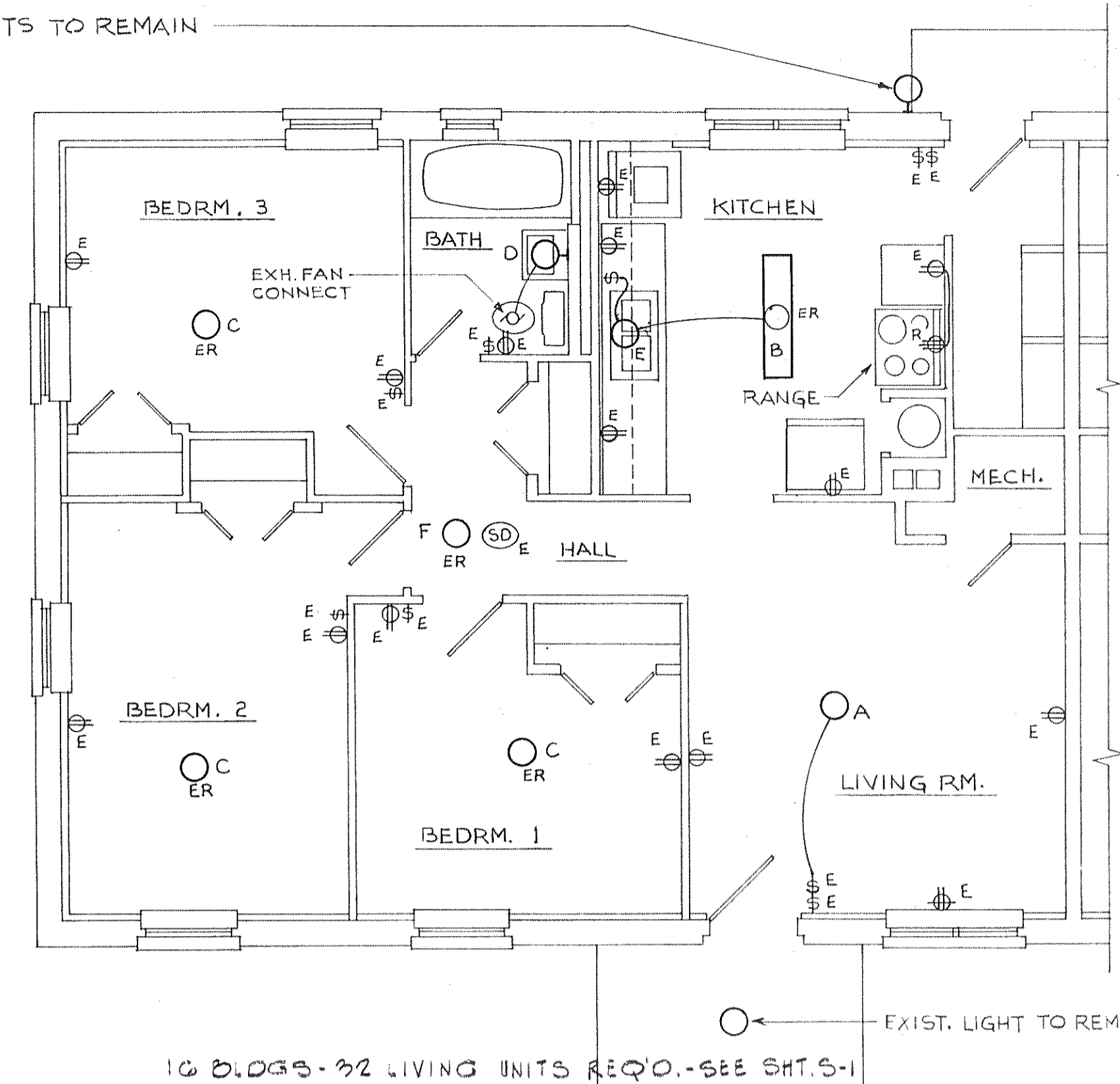

BLOG. "C" FLOOR PLAN

1/4" = 1'-0"

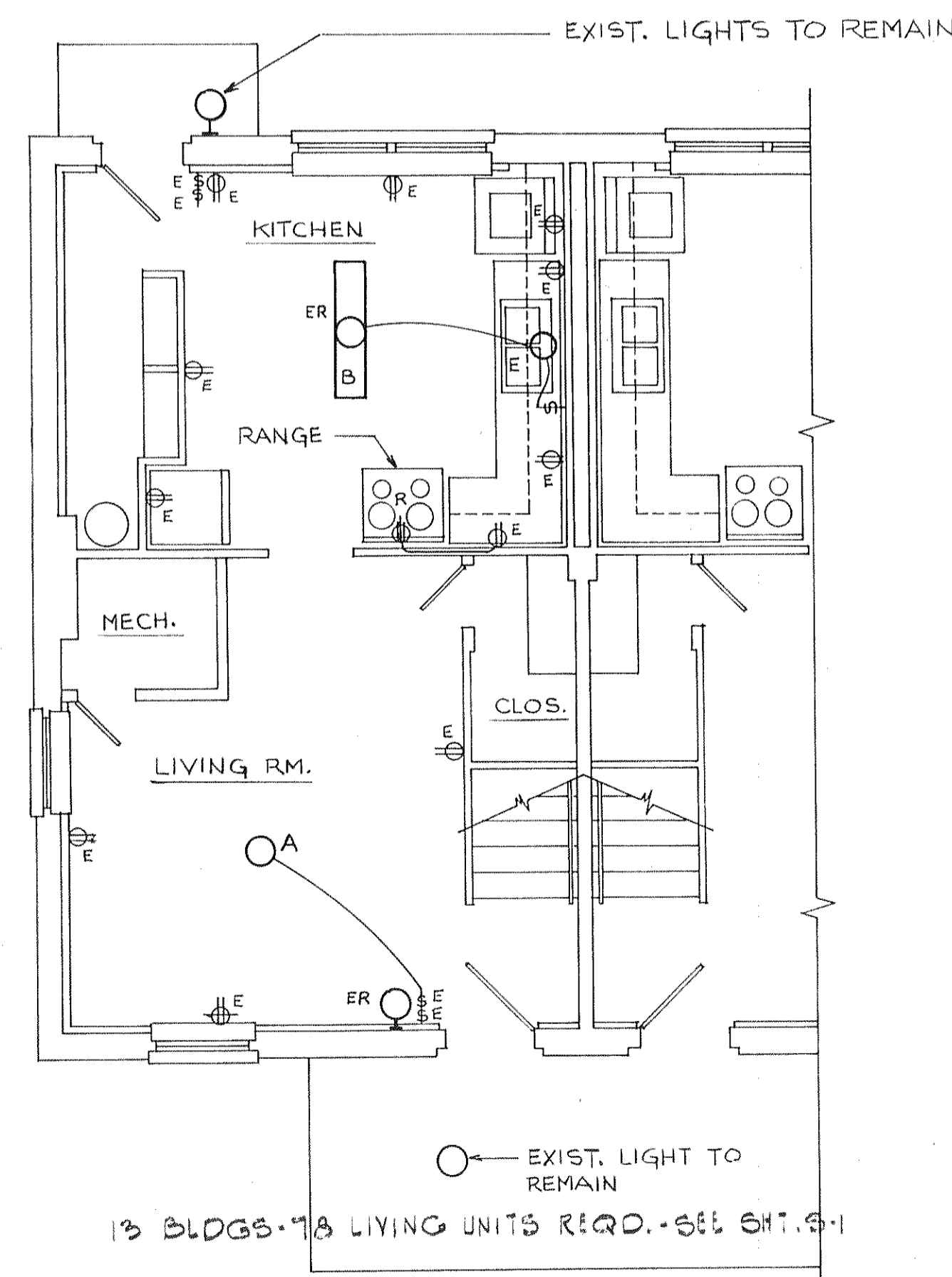

BLOG. "A" FIRST FLOOR PLAN

1/4" = 1'-0"

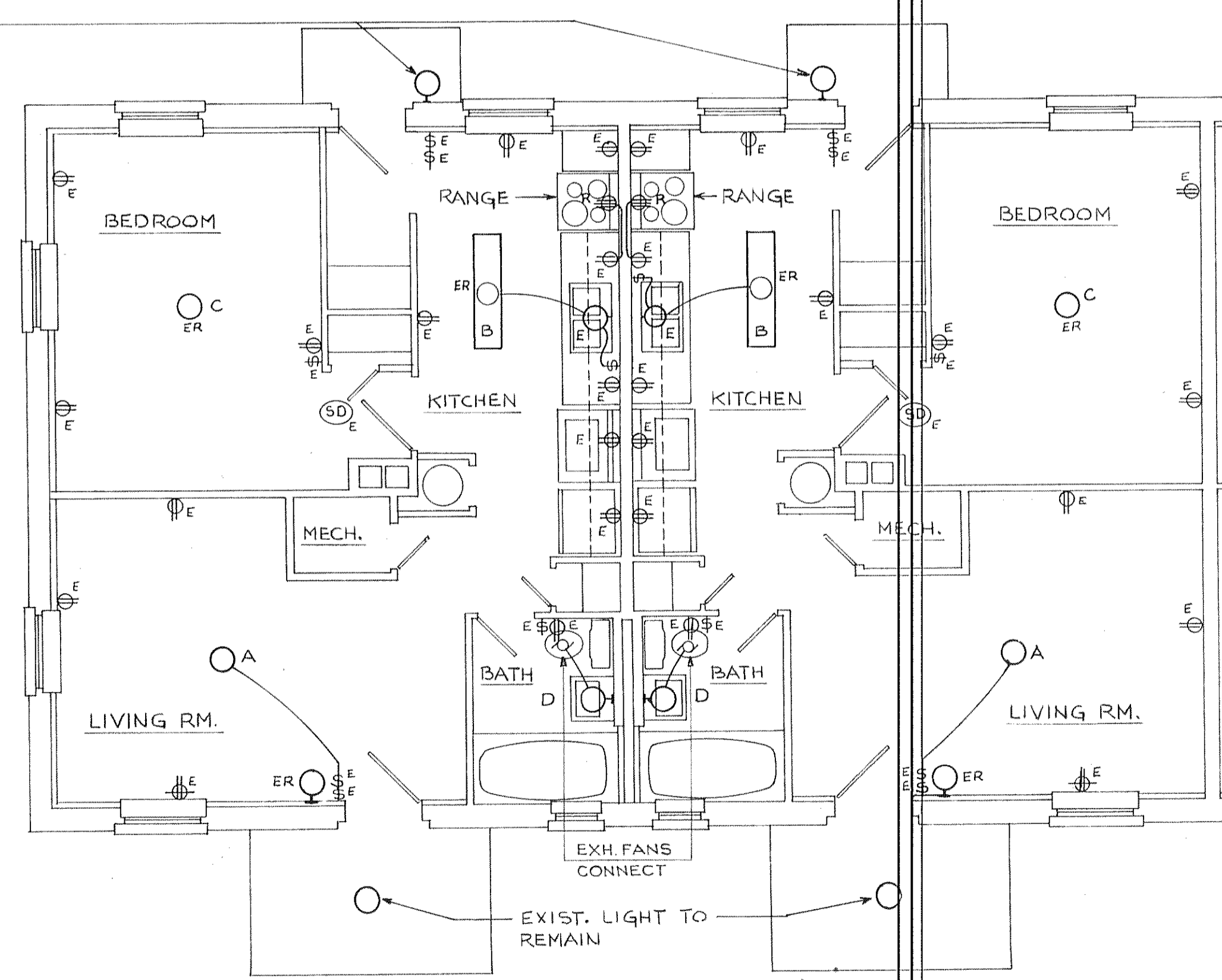

BLOG. "D" FLOOR PLAN

1/4" = 1'-0"

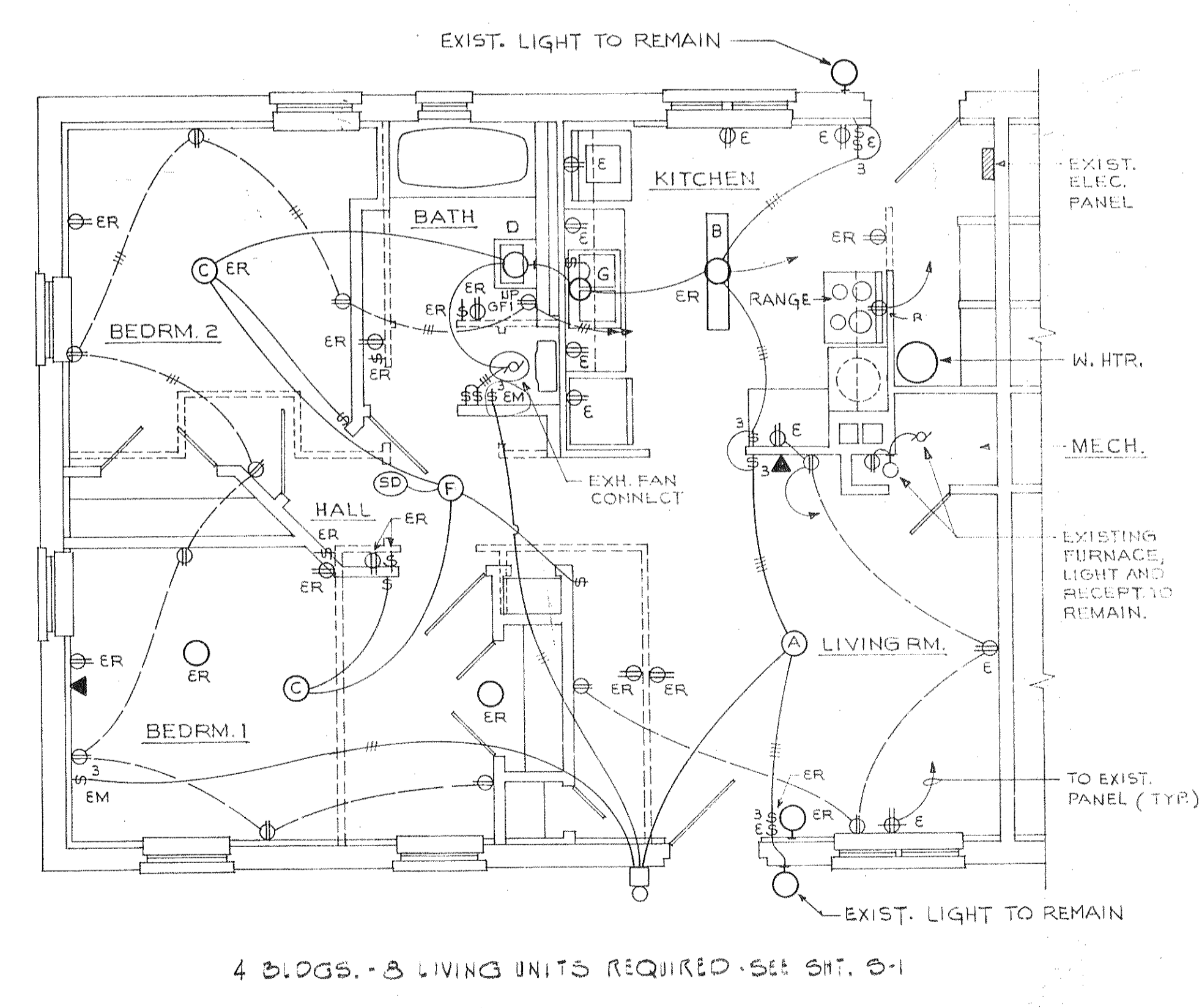

BUILDING "H" FLOOR PLAN

1/4" = 1'-0"

EXIST. LIGHTS TO REMAIN

EXIST. LIGHTS TO REMAIN

EXIST. LIGHT TO REMAIN

EXIST. LIGHTS TO REMAIN

EXIST. LIGHT TO REMAIN

EXIST. ELEC. PANEL

W. HTR.

MECH.

EXISTING FURNACE, LIGHT AND RECEPT TO REMAIN.

TO EXIST. PANEL (TYP.)

EXIST. LIGHT TO REMAIN

EXIST. LIGHT TO REMAIN

4 BLDGS. - 8 LIVING UNITS REQUIRED - SEE SH. S-1

12 BLDGS. - 24 LIVING UNITS REQD. - SEE SH. S-1

16 BLDGS. - 92 LIVING UNITS REQD. - SEE SH. S-1

EXIST. LIGHT TO REMAIN

13 BLDGS. - 18 LIVING UNITS REQD. - SEE SH. S-1

5 BLDGS. - 30 LIVING UNITS REQD. - SEE SH. S-1

PHASE 2 CONSTRUCTION
 MODERNIZATION OF DANIEL BROOKS HOMES, NC 9-2
 PROJECT PLAN C-905
 HOUSING AUTHORITY OF THE CITY OF HIGH POINT

CONTENTS
 ELECTRICAL
 FLOOR PLANS

ALLRED & MERCER ARCHITECTS, INC.
 MEMBERS OF THE AMERICAN INSTITUTE OF ARCHITECTS
 THE LEGAL CENTER - HIGH POINT, N. C. 27601 - TELEPHONE 885-0033

COMMA NO. 84
 DATE: 12-1-67
 SHEET NO.
 OF 2 TOTAL



Development: Daniel Brooks Homes
Building Number: 319 Henley Ave.
Description: Yard View Near 319 Henley Ave.
Photographer: High Point Housing Authority
Date Taken: June 14, 2019
Digital Photo: 319 Henley Ave. Front View



Development: Daniel Brooks Homes
Building Number: 319 Henley Ave.
Description: Fairview Near 319 Henley Ave.
Photographer: High Point Housing Authority
Date Taken: June 14, 2019
Digital Photo: 319 Henley Ave. Front View



Development: Daniel Brooks Homes
Building Number: 329-B Henley St.
Description: Unit Type B
Photographer: High Point Housing Authority
Date Taken: June 14, 2019
Digital Photo: 329-B Henley St. Unit Type B1



Development: Daniel Brooks Homes
Building Number: 329-B Henley St.
Description: Unit Type B
Photographer: High Point Housing Authority
Date Taken: June 14, 2019
Digital Photo: 329-B Henley St. Unit Type B2



Development: Daniel Brooks Homes
Building Number: 329-B Henley St.
Description: Unit Type B
Photographer: High Point Housing Authority
Date Taken: June 14, 2019
Digital Photo: 329-B Henley St. Unit Type B3



Development: Daniel Brooks Homes
Building Number: 329-B Henley St.
Description: Unit Type B
Photographer: High Point Housing Authority
Date Taken: June 14, 2019
Digital Photo: 329-B Henley St. Unit Type B4



Development: Daniel Brooks Homes
Building Number: 329-B Henley St.
Description: Unit Type B
Photographer: High Point Housing Authority
Date Taken: June 14, 2019
Digital Photo: 329-B Henley St. Unit Type B5



Development: Daniel Brooks Homes
Building Number: 329-B Henley St.
Description: Unit Type B
Photographer: High Point Housing Authority
Date Taken: June 14, 2019
Digital Photo: 329-B Henley St. Unit Type B6



Development: Daniel Brooks Homes
Building Number: 329-B Henley St.
Description: Unit Type B
Photographer: High Point Housing Authority
Date Taken: June 14, 2019
Digital Photo: 329-B Henley St. Unit Type B7



Development: Daniel Brooks Homes
Building Number: 329-B Henley St.
Description: Unit Type B
Photographer: High Point Housing Authority
Date Taken: June 14, 2019
Digital Photo: 329-B Henley St. Unit Type B8



Development: Daniel Brooks Homes
Building Number: 329-B Henley St.
Description: Unit Type B
Photographer: High Point Housing Authority
Date Taken: June 14, 2019
Digital Photo: 329-B Henley St. Unit Type B9



Development: Daniel Brooks Homes
Building Number: 329-B Henley St.
Description: Unit Type B
Photographer: High Point Housing Authority
Date Taken: June 14, 2019
Digital Photo: 329-B Henley St. Unit Type B10



Development: Daniel Brooks Homes
Building Number: 329-B Henley St.
Description: Unit Type B
Photographer: High Point Housing Authority
Date Taken: June 14, 2019
Digital Photo: 329-B Henley St. Unit Type B11



Development: Daniel Brooks Homes

Building Number: 329-B Henley St.

Description: Unit Type B

Photographer: High Point Housing Authority

Date Taken: June 14, 2019

Digital Photo: 329-B Henley St. Unit Type B12



Development: Daniel Brooks Homes
Building Number: 1413 West Ave.
Description: Unit Type C
Photographer: High Point Housing Authority
Date Taken: June 14, 2019
Digital Photo: 1413 West Ave. Unit Type C1



**Daniel Brooks Homes
Public Housing Historic Recordation
Housing Authority of the City of High Point**

September 5, 2019

Historical Background

The Daniel Brooks Homes community was constructed in 1942 and is the oldest property the Housing Authority of the City of High Point (HPHA) portfolio. This community consist of 172 housing units. The property was named in honor of Rev. Daniel Brooks for his service to the community. Rev. Brooks was a Methodist Minister in High Point and served multiple terms as a city school commissioner. He is best known best for negotiating the sale of land that later became the historic William Penn High School in High Point, North Carolina. Tyson Ferree, a prominent local architect, patterned the design for Daniel Brooks Homes based on mid-nineteenth century English worker housing; including signature stone walls, steep-pitched roofs, distinctive chimneys, and meandering greenways.



Development: Daniel Brooks Homes
Building Number: NA
Description: Neighborhood Entrance Sign
Photographer: High Point Housing Authority
Date Taken: June 14, 2019
Digital Photo: Daniel Brooks Entrance

Daniel Brooks Entrance

Daniel Brooks Homes was developed as designated as an African American community in accordance with segregation laws of the time. HPHA borrowed \$1,770,000 funds from the United States Housing Administration to clear areas, that qualified as slums, to create new neighborhoods of apartments in their place. HPHA moved forward with two “separate but equal” projects. On the east side of the city, a site for Daniel Brooks Homes was selected near William Penn High School. Clara Cox, a slightly larger complex of 250 units located between Asheboro, Park, and E. Russell Ave., was reserved for whites only. Both projects were completed in 1942.

The construction of Daniel Brooks Homes and its design articulated social reform ideals of the day. These design ideals sought to engineer resident behavior in ways anticipated to improve their lives with attention to safety, proximity to nature, social interaction, and order. Tyson Ferree worked closely with the landscape architect, Reginald D. Tillson, to configure units with direct access to a network of curvilinear greenways that

were flanked by lawns, shrubs, and trees. These greenways would not only improve the health of residents, by encouraging walking, but also increase the frequency of social interaction. The incorporation of gently curving walkways separate from roads was part of the “garden city” ideal, first expressed in Great Britain, where clusters of buildings were surrounded by open spaces or village greens in contrast to the dense urban and industrial landscapes typical of manufactured cities.



Aerial View of Daniel Brooks

Daniel Brooks Homes also sought to provide a solution to the substandard and crowded housing conditions experienced in High Point during the 1930s. In contrast to market-rate residences that existed across the city, these federally financed units could be operated by HPHA based on need and income thresholds.

Daniel Brooks Homes buildings and unit types are broken down as follows:

Daniel Brooks Core Community (1942)							
Unit Types	Bedrooms	Stories	Sample Location	Sq.ft.	Entrances	Total Buildings	Total Units
A	2	2	1459-A West	723.34	6	13	78
B	1	1	1433-B West	456.74	2	12	24
C	3	1	1457-A West	762.75	2	16	32
D	1	1	321-C Henley	456.74	6	5	30
H	2	1	1429-A West	767.41	2	4	8
					Total	50	172

- Type A** This is a 2-story rowhome style building that consist of 6 dwelling units with 2 bedrooms and 1 bathroom located on the second level.
- Type B** This is a 1-story duplex that consist of 2 dwelling units with 1 bedroom and 1 bathroom.
- Type C** This is a 1-story duplex that consist of 2 dwelling units with 1 bedroom and 1 bathroom.
- Type D** This is a 1-story rowhome style building that consist of 6 dwelling units with 1 bedroom and 1 bathroom.
- Type H** This is a 1-story duplex that consist of 2 dwelling units with 1 bedroom and 1 bathroom.

Sketch Plan of Development



Site Plan Development

Streetscapes and Amenities



Development: Daniel Brooks Homes
Building Number: 1443 West Ave.
Description: Street View of the 1400 Block of West Ave.
Photographer: High Point Housing Authority
Date Taken: June 14, 2019
Digital Photo: 1443 West Street View



Development: Daniel Brooks Homes
Building Number: 1479 West Ave.
Description: Yard View of the 1400 Block of West Ave.
Photographer: High Point Housing Authority
Date Taken: June 14, 2019
Digital Photo: 1479 West Green Space

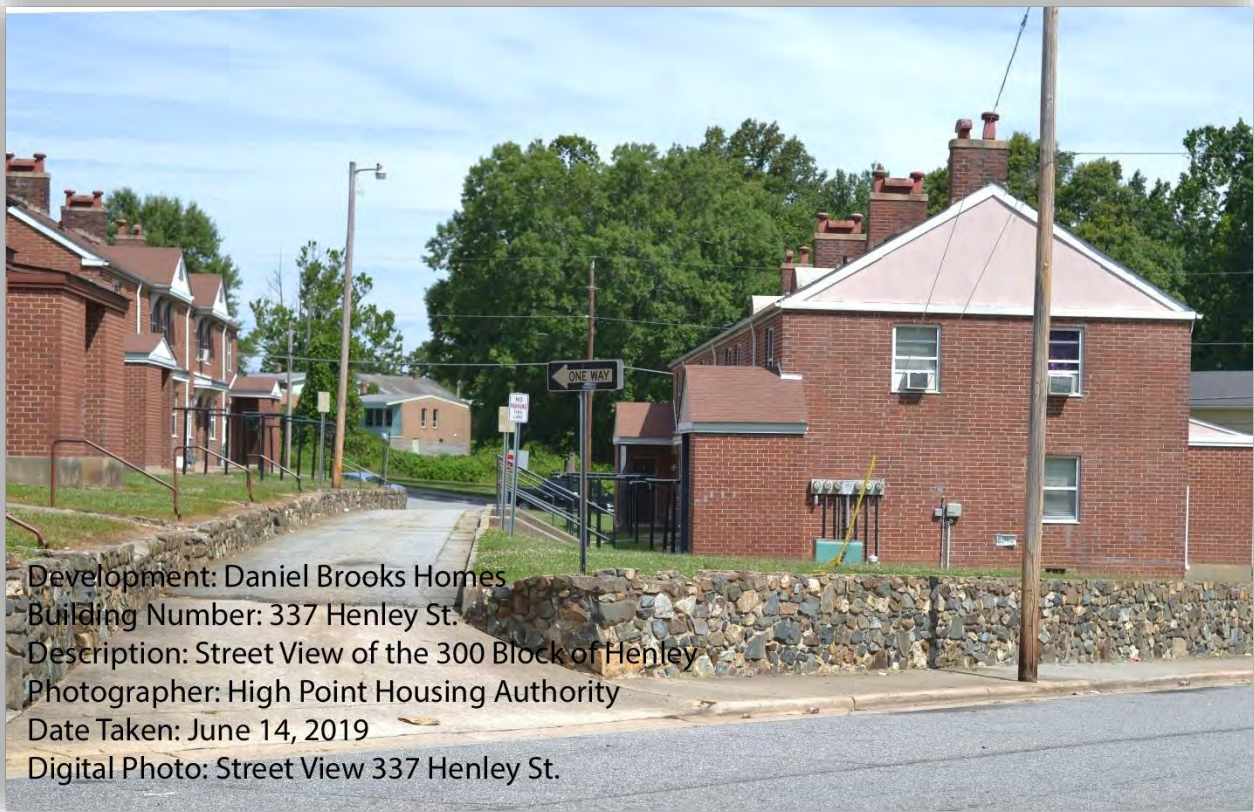

Development: Daniel Brooks Homes
Building Number: 337 Henley St.
Description: Street View of the 300 Block of Henley
Photographer: High Point Housing Authority
Date Taken: June 14, 2019
Digital Photo: Street View 337 Henley St.

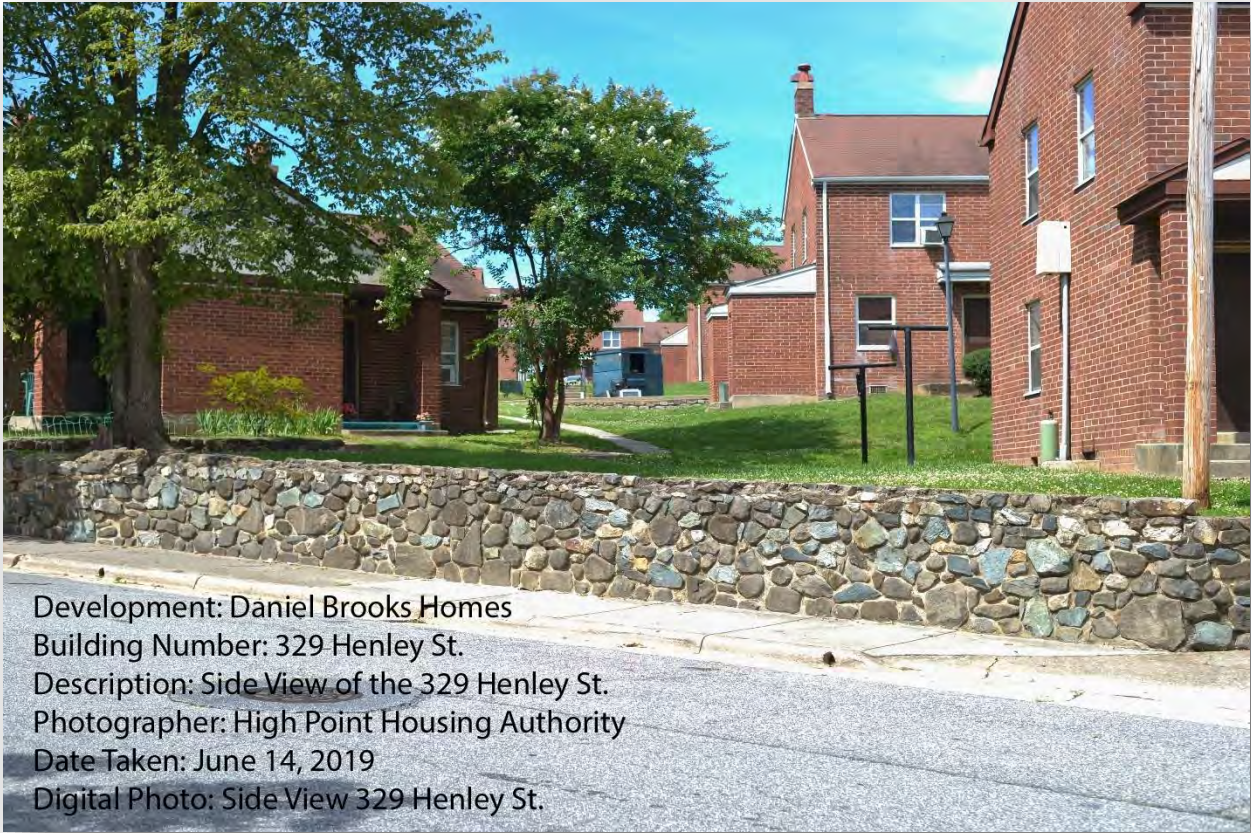

Development: Daniel Brooks Homes
Building Number: 329 Henley St.
Description: Side View of the 329 Henley St.
Photographer: High Point Housing Authority
Date Taken: June 14, 2019
Digital Photo: Side View 329 Henley St.



Development: Daniel Brooks Homes
Building Number: 1447 West Ave.
Description: Yard View 1447 West Ave.
Photographer: High Point Housing Authority
Date Taken: June 14, 2019
Digital Photo: Green Space 1447 West Ave.



Development: Daniel Brooks Homes
Building Number: 1453 West Ave.
Description: Daniel Brooks Day Care Sign
Photographer: High Point Housing Authority
Date Taken: June 14, 2019
Digital Photo: Day Care Sign



Development: Daniel Brooks Homes
Building Number: 1453 West Ave.
Description: Yard View Daniel Brooks Day Care
Photographer: High Point Housing Authority
Date Taken: June 14, 2019
Digital Photo: Day Care Yard View



Development: Daniel Brooks Homes
Building Number: 1453 West Ave.
Description: Front View Daniel Brooks Day Care
Photographer: High Point Housing Authority
Date Taken: June 14, 2019
Digital Photo: Day Care Front View



Development: Daniel Brooks Homes
Building Number: 1455 West Ave.
Description: Daniel Brooks Community Center
Photographer: High Point Housing Authority
Date Taken: June 14, 2019
Digital Photo: Daniel Brooks Community Center Interior



Development: Daniel Brooks Homes
Building Number: 319 Henley Ave.
Description: front view Near 319 Henley Ave.
Photographer: High Point Housing Authority
Date Taken: June 14, 2019
Digital Photo: 319 Henley Ave. Front View



Development: Daniel Brooks Homes
Building Number: 337 Henley St.
Description: Street View of the 300 Block of Henley
Photographer: High Point Housing Authority
Date Taken: June 14, 2019
Digital Photo: Street View 337 Henley St.



Development: Daniel Brooks Homes
Building Number: 327 Henley St.
Description: Street View of the 327 Henley St.
Photographer: High Point Housing Authority
Date Taken: June 14, 2019
Digital Photo: Street View 327 Henley St.

Significant Landmarks



Development: Daniel Brooks Homes
Building Number: 1455 West Ave.
Description: Daniel Brooks Community Plaque
Photographer: High Point Housing Authority
Date Taken: June 14, 2019
Digital Photo: Daniel Brooks Community Plaque



Development: Daniel Brooks Homes
Building Number: 1455 West Ave
Description: Daniel Brooks Honorary Flagpole
Photographer: High Point Housing Authority
Date Taken: June 14, 2019
Digital Photo: Daniel Brooks Honorary Flagpole



Development: Daniel Brooks Homes
Building Number: NA
Description: Intricate Stone Retainer Walls
Photographer: High Point Housing Authority
Date Taken: June 14, 2019
Digital Photo: Intricate Stone Retainer Walls 1



Development: Daniel Brooks Homes
Building Number: NA
Description: Intricate Stone Retainer Walls
Photographer: High Point Housing Authority
Date Taken: June 14, 2019
Digital Photo: Intricate Stone Retainer Walls 2



Development: Daniel Brooks Homes
Building Number: NA
Description: Intricate Stone Retainer Walls
Photographer: High Point Housing Authority
Date Taken: June 14, 2019
Digital Photo: Intricate Stone Retainer Walls 3



Development: Daniel Brooks Homes
Building Number: NA
Description: Intricate Stone Retainer Walls
Photographer: High Point Housing Authority
Date Taken: June 14, 2019
Digital Photo: Intricate Stone Retainer Walls 4

Unit Type A (1459 West Ave.)

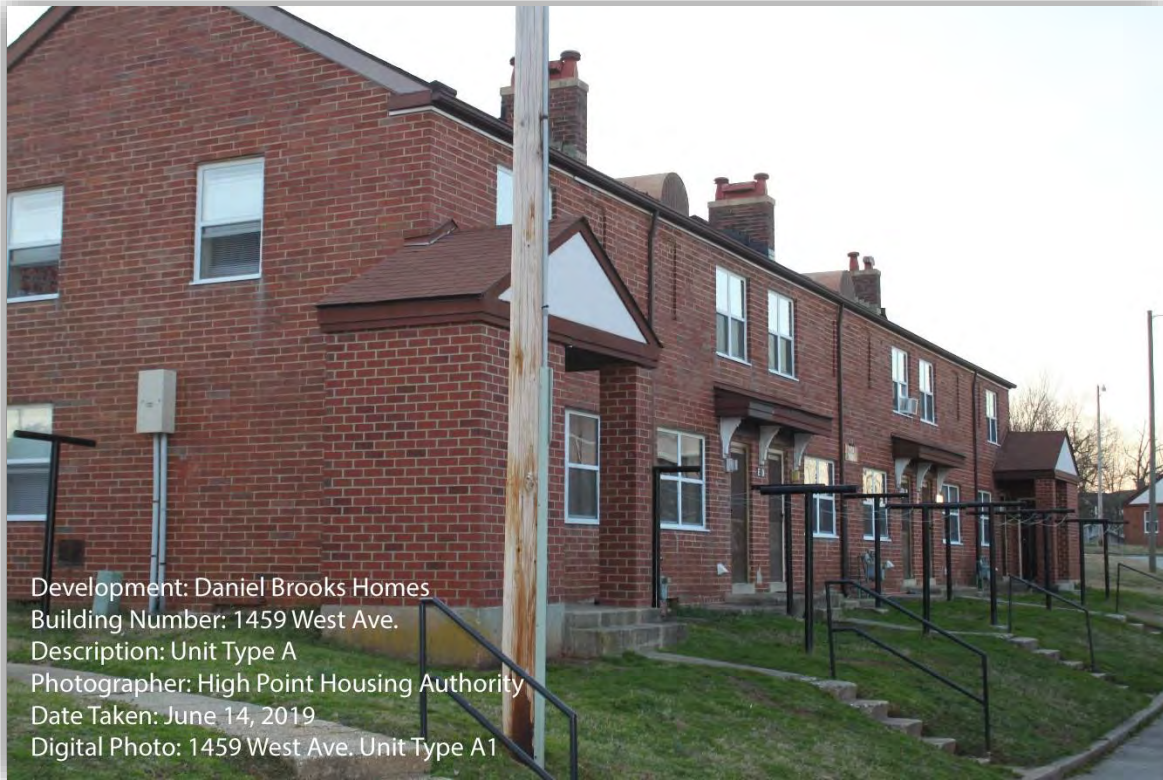



Development: Daniel Brooks Homes
Building Number: 1459 West Ave.
Description: Unit Type A
Photographer: High Point Housing Authority
Date Taken: June 14, 2019
Digital Photo: 1459 West Ave. Unit Type A3



Development: Daniel Brooks Homes
Building Number: 1459 West Ave.
Description: Unit Type A
Photographer: High Point Housing Authority
Date Taken: June 14, 2019
Digital Photo: 1459 West Ave. Unit Type A4



Development: Daniel Brooks Homes
Building Number: 1459 West Ave.
Description: Unit Type A
Photographer: High Point Housing Authority
Date Taken: June 14, 2019
Digital Photo: 1459 West Ave. Unit Type A5



Development: Daniel Brooks Homes
Building Number: 1459 West Ave.
Description: Unit Type A
Photographer: High Point Housing Authority
Date Taken: June 14, 2019
Digital Photo: 1459 West Ave. Unit Type A6

Unit Type B (329 Henley St.)





Development: Daniel Brooks Homes
Building Number: 329-B Henley St.
Description: Unit Type B
Photographer: High Point Housing Authority
Date Taken: June 14, 2019
Digital Photo: 329-B Henley St. Unit Type B3



Development: Daniel Brooks Homes
Building Number: 329-B Henley St.
Description: Unit Type B
Photographer: High Point Housing Authority
Date Taken: June 14, 2019
Digital Photo: 329-B Henley St. Unit Type B4



Development: Daniel Brooks Homes
Building Number: 329-B Henley St.
Description: Unit Type B
Photographer: High Point Housing Authority
Date Taken: June 14, 2019
Digital Photo: 329-B Henley St. Unit Type B5

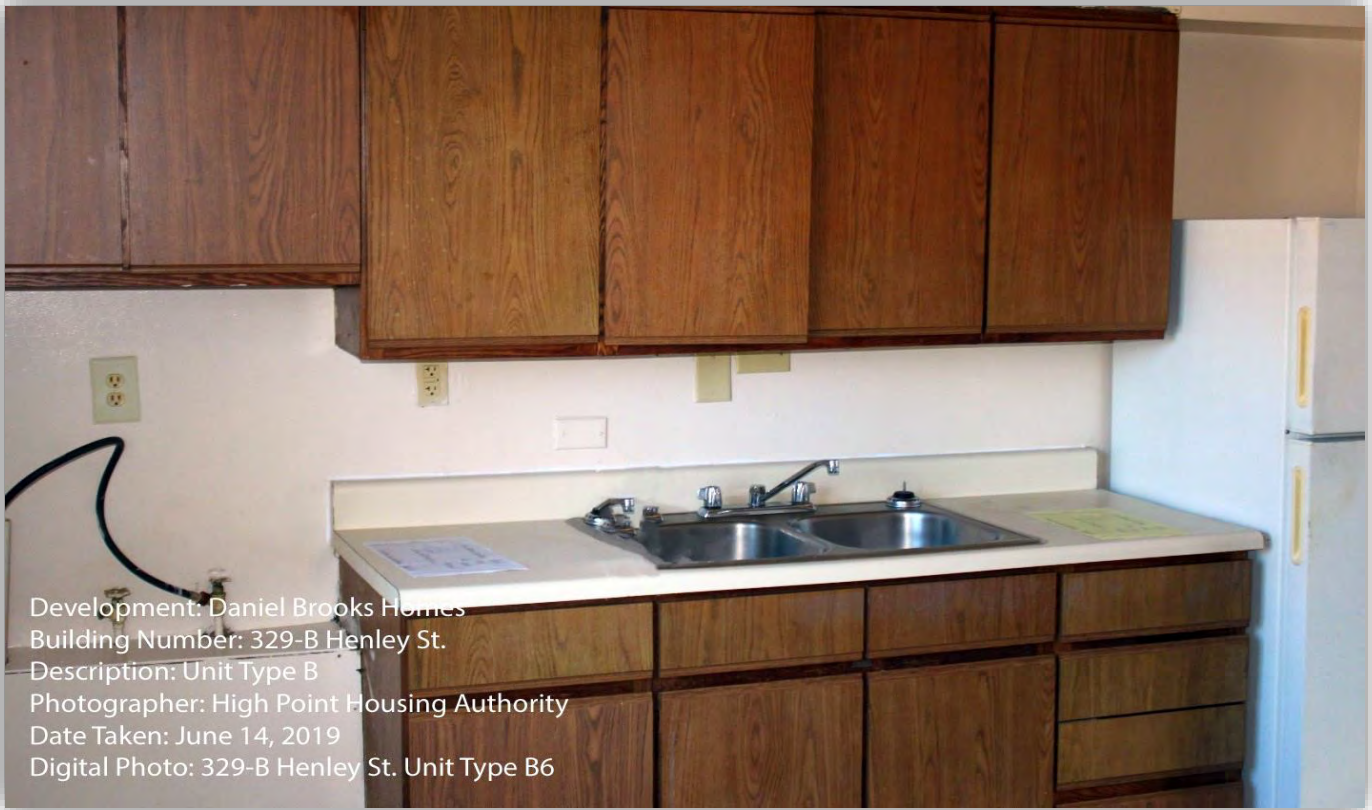

Development: Daniel Brooks Homes
Building Number: 329-B Henley St.
Description: Unit Type B
Photographer: High Point Housing Authority
Date Taken: June 14, 2019
Digital Photo: 329-B Henley St. Unit Type B6



Development: Daniel Brooks Homes
Building Number: 329-B Henley St.
Description: Unit Type B
Photographer: High Point Housing Authority
Date Taken: June 14, 2019
Digital Photo: 329-B Henley St. Unit Type B11



Development: Daniel Brooks Homes
Building Number: 329-B Henley St.
Description: Unit Type B
Photographer: High Point Housing Authority
Date Taken: June 14, 2019
Digital Photo: 329-B Henley St. Unit Type B8

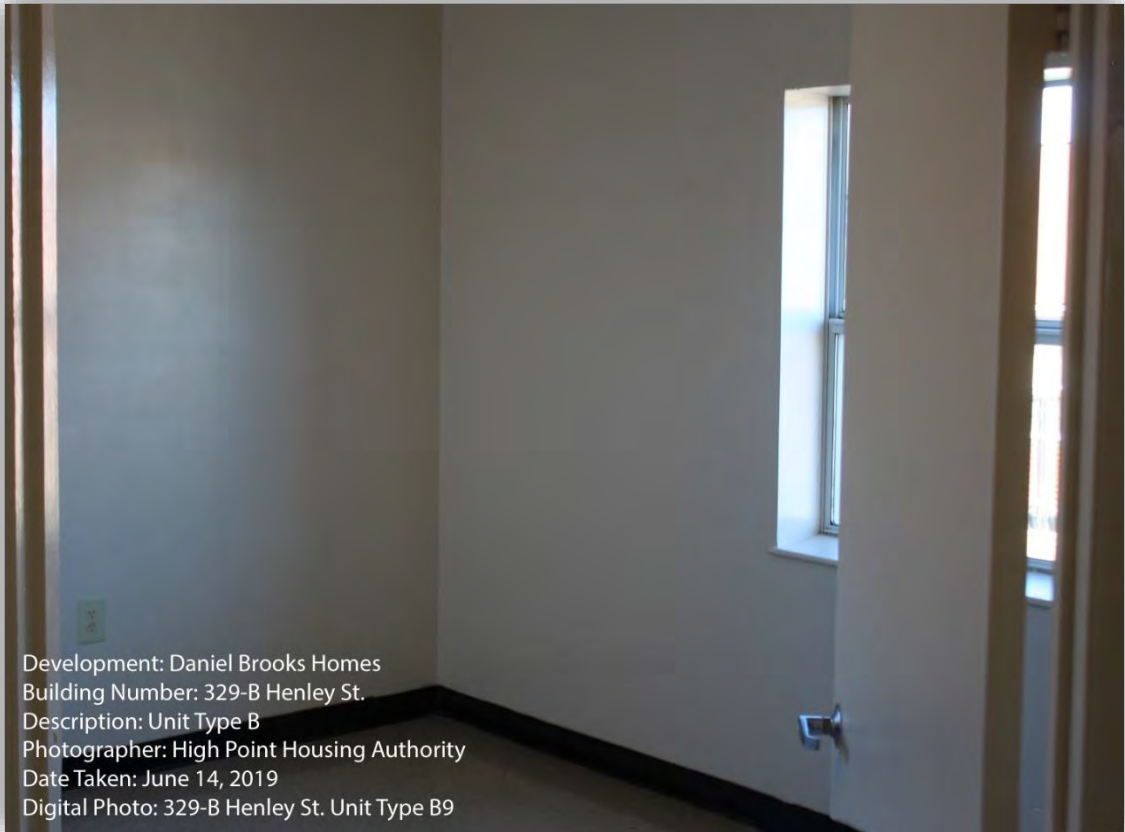

Development: Daniel Brooks Homes
Building Number: 329-B Henley St.
Description: Unit Type B
Photographer: High Point Housing Authority
Date Taken: June 14, 2019
Digital Photo: 329-B Henley St. Unit Type B9



Development: Daniel Brooks Homes
Building Number: 329-B Henley St.
Description: Unit Type B
Photographer: High Point Housing Authority
Date Taken: June 14, 2019
Digital Photo: 329-B Henley St. Unit Type B10



Development: Daniel Brooks Homes
Building Number: 329-B Henley St.
Description: Unit Type B
Photographer: High Point Housing Authority
Date Taken: June 14, 2019
Digital Photo: 329-B Henley St. Unit Type B11

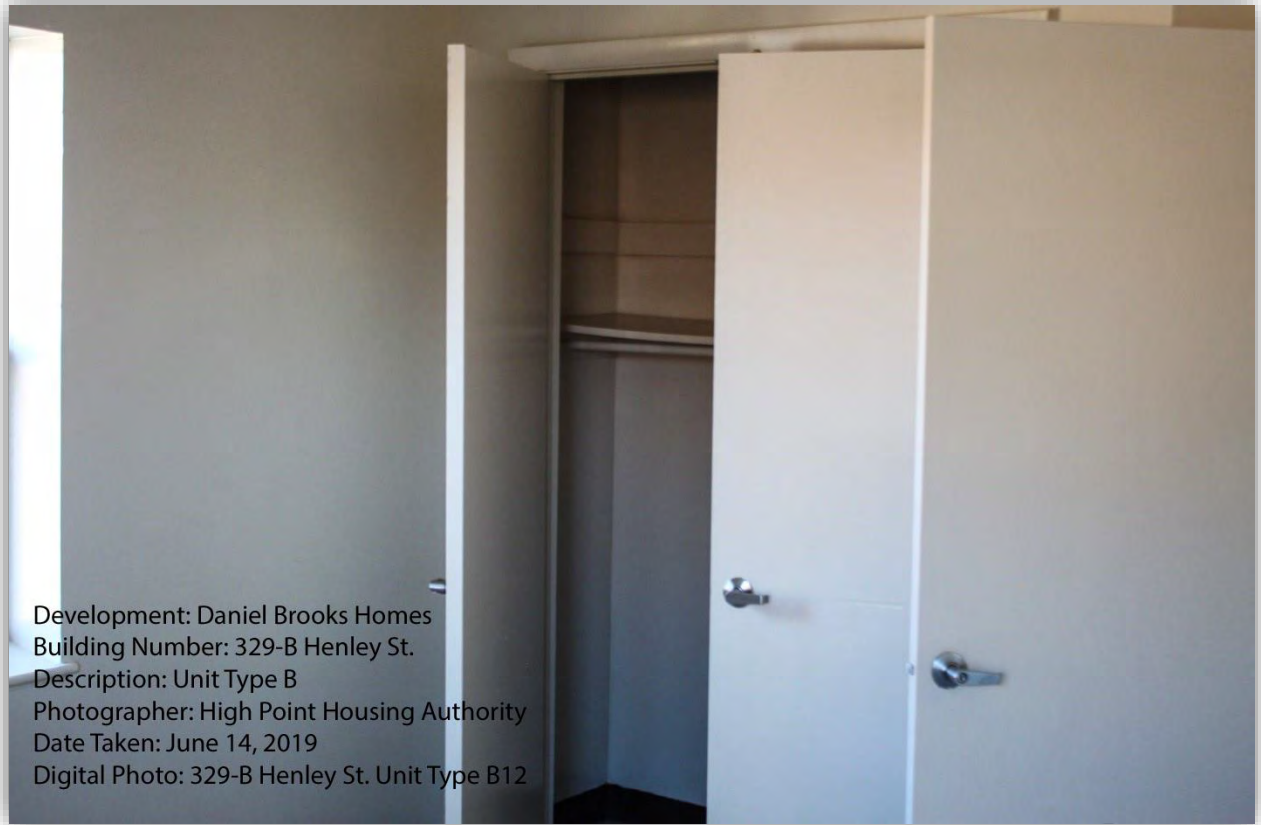

Development: Daniel Brooks Homes
Building Number: 329-B Henley St.
Description: Unit Type B
Photographer: High Point Housing Authority
Date Taken: June 14, 2019
Digital Photo: 329-B Henley St. Unit Type B12

Unit Type C (1413 West Ave.)



Development: Daniel Brooks Homes
Building Number: 1413 West Ave.
Description: Unit Type C
Photographer: High Point Housing Authority
Date Taken: June 14, 2019
Digital Photo: 1413 West Ave. Unit Type C1



Development: Daniel Brooks Homes
Building Number: 1413 West Ave.
Description: Unit Type C
Photographer: High Point Housing Authority
Date Taken: June 14, 2019
Digital Photo: 1413 West Ave. Unit Type C2



Development: Daniel Brooks Homes
Building Number: 1413 West Ave.
Description: Unit Type C
Photographer: High Point Housing Authority
Date Taken: June 14, 2019
Digital Photo: 1413 West Ave. Unit Type C3



Development: Daniel Brooks Homes
Building Number: 1413 West Ave.
Description: Unit Type C
Photographer: High Point Housing Authority
Date Taken: June 14, 2019
Digital Photo: 1413 West Ave. Unit Type C4

Unit Type H (1429 West Ave.)



Development: Daniel Brooks Homes
Building Number: 1429 West Ave.
Description: Unit Type H
Photographer: High Point Housing Authority
Date Taken: June 14, 2019
Digital Photo: 1429 West Ave. Unit Type H1



Development: Daniel Brooks Homes
Building Number: 1429 West Ave.
Description: Unit Type H
Photographer: High Point Housing Authority
Date Taken: June 14, 2019
Digital Photo: 1429 West Ave. Unit Type H2



Development: Daniel Brooks Homes
Building Number: 1429 West Ave.
Description: Unit Type H
Photographer: High Point Housing Authority
Date Taken: June 14, 2019
Digital Photo: 1429 West Ave. Unit Type H3



Development: Daniel Brooks Homes
Building Number: 1429 West Ave.
Description: Unit Type H
Photographer: High Point Housing Authority
Date Taken: June 14, 2019
Digital Photo: 1429 West Ave. Unit Type H4



Development: Daniel Brooks Homes
Building Number: 1429 West Ave.
Description: Unit Type H
Photographer: High Point Housing Authority
Date Taken: June 14, 2019
Digital Photo: 1429 West Ave. Unit Type H5



Development: Daniel Brooks Homes
Building Number: 1429 West Ave.
Description: Unit Type H
Photographer: High Point Housing Authority
Date Taken: June 14, 2019
Digital Photo: 1429 West Ave. Unit Type H5



Development: Daniel Brooks Homes
Building Number: 1429 West Ave.
Description: Unit Type H
Photographer: High Point Housing Authority
Date Taken: June 14, 2019
Digital Photo: 1429 West Ave. Unit Type H7



Development: Daniel Brooks Homes
Building Number: 1429 West Ave.
Description: Unit Type H
Photographer: High Point Housing Authority
Date Taken: June 14, 2019
Digital Photo: 1429 West Ave. Unit Type H8



Development: Daniel Brooks Homes
Building Number: 1413 West Ave.
Description: Unit Type C
Photographer: High Point Housing Authority
Date Taken: June 14, 2019
Digital Photo: 1413 West Ave. Unit Type C2



Development: Daniel Brooks Homes
Building Number: 1413 West Ave.
Description: Unit Type C
Photographer: High Point Housing Authority
Date Taken: June 14, 2019
Digital Photo: 1413 West Ave. Unit Type C3



Development: Daniel Brooks Homes
Building Number: 1413 West Ave.
Description: Unit Type C
Photographer: High Point Housing Authority
Date Taken: June 14, 2019
Digital Photo: 1413 West Ave. Unit Type C4



Development: Daniel Brooks Homes
Building Number: 1429 West Ave.
Description: Unit Type H
Photographer: High Point Housing Authority
Date Taken: June 14, 2019
Digital Photo: 1429 West Ave. Unit Type H1



Development: Daniel Brooks Homes
Building Number: 1429 West Ave.
Description: Unit Type H
Photographer: High Point Housing Authority
Date Taken: June 14, 2019
Digital Photo: 1429 West Ave. Unit Type H2



Development: Daniel Brooks Homes

Building Number: 1429 West Ave.

Description: Unit Type H

Photographer: High Point Housing Authority

Date Taken: June 14, 2019

Digital Photo: 1429 West Ave. Unit Type H3



Development: Daniel Brooks Homes
Building Number: 1429 West Ave.
Description: Unit Type H
Photographer: High Point Housing Authority
Date Taken: June 14, 2019
Digital Photo: 1429 West Ave. Unit Type H4



Development: Daniel Brooks Homes
Building Number: 1429 West Ave.
Description: Unit Type H
Photographer: High Point Housing Authority
Date Taken: June 14, 2019
Digital Photo: 1429 West Ave. Unit Type H5



Development: Daniel Brooks Homes
Building Number: 1429 West Ave.
Description: Unit Type H
Photographer: High Point Housing Authority
Date Taken: June 14, 2019
Digital Photo: 1429 West Ave. Unit Type H



Development: Daniel Brooks Homes

Building Number: 1429 West Ave.

Description: Unit Type H

Photographer: High Point Housing Authority

Date Taken: June 14, 2019

Digital Photo: 1429 West Ave. Unit Type H7



Development: Daniel Brooks Homes
Building Number: 1429 West Ave.
Description: Unit Type H
Photographer: High Point Housing Authority
Date Taken: June 14, 2019
Digital Photo: 1429 West Ave. Unit Type H8



Development: Daniel Brooks Homes

Building Number: 1443 West Ave.

Description: Street View of the 1400 Block of West Ave.

Photographer: High Point Housing Authority

Date Taken: June 14, 2019

Digital Photo: 1443 West Street View



Development: Daniel Brooks Homes

Building Number: 1443 West Ave.

Description: Street View of the 1400 Block of West Ave.

Photographer: High Point Housing Authority

Date Taken: June 14, 2019

Digital Photo: 1443 West Street View



Development: Daniel Brooks Homes
Building Number: 1459 West Ave.
Description: Unit Type A
Photographer: High Point Housing Authority
Date Taken: June 14, 2019
Digital Photo: 1459 West Ave. Unit Type A1



Development: Daniel Brooks Homes
Building Number: 1459 West Ave.
Description: Unit Type A
Photographer: High Point Housing Authority
Date Taken: June 14, 2019
Digital Photo: 1459 West Ave. Unit Type A2



Development: Daniel Brooks Homes
Building Number: 1459 West Ave.
Description: Unit Type A
Photographer: High Point Housing Authority
Date Taken: June 14, 2019
Digital Photo: 1459 West Ave. Unit Type A3



Development: Daniel Brooks Homes
Building Number: 1459 West Ave.
Description: Unit Type A
Photographer: High Point Housing Authority
Date Taken: June 14, 2019
Digital Photo: 1459 West Ave. Unit Type A4



Development: Daniel Brooks Homes
Building Number: 1459 West Ave.
Description: Unit Type A
Photographer: High Point Housing Authority
Date Taken: June 14, 2019
Digital Photo: 1459 West Ave. Unit Type A5



Development: Daniel Brooks Homes
Building Number: 1459 West Ave.
Description: Unit Type A
Photographer: High Point Housing Authority
Date Taken: June 14, 2019
Digital Photo: 1459 West Ave. Unit Type A6



Development: Daniel Brooks Homes
Building Number: 1455 West Ave.
Description: Daniel Brooks Community Center
Photographer: High Point Housing Authority
Date Taken: June 14, 2019
Digital Photo: Daniel Brooks Community Center Interior

DANIEL BROOKS HOMES

BUILT BY
HOUSING AUTHORITY OF THE CITY OF
HIGH POINT, NORTH CAROLINA
WITH THE ASSISTANCE OF
THE UNITED STATES HOUSING AUTHORITY

FRANKLIN D. ROOSEVELT
PRESIDENT OF THE UNITED STATES OF AMERICA

JOHN M. CARMODY **NATHAN STRAUS**
ADMINISTRATOR OF THE ADMINISTRATOR OF THE
FEDERAL WORKS AGENCY U.S. HOUSING AUTHORITY

WITH THE COOPERATION OF THE
CITY OF HIGH POINT

O. ARTHUR KIRKMAN
MAYOR

HOUSING AUTHORITY OF THE
CITY OF HIGH POINT

CARUS W. WAINWRIGHT CHAIRMAN
J. E. WELLS VICE CHAIRMAN
REYD. L. RUBY **D. A. DOWDY**
REV. F. L. CONRAD
COMMISSIONERS

J. G. D. COX EXECUTIVE DIRECTOR

ARCHITECT LANDSCAPE ARCHITECT
TYSON T. FERREE **R. D. TILLSON**

CONTRACTOR
P. S. WEST CONST. CO., INC.
1941

Development: Daniel Brooks Homes

Building Number: 1455 West Ave.

Description: Daniel Brooks Community Plaque

Photographer: High Point Housing Authority

Date Taken: June 14, 2019

Digital Photo: Daniel Brooks Community Plaque



Development: Daniel Brooks Homes
Building Number: NA
Description: Neighborhood Entrance Sign
Photographer: High Point Housing Authority
Date Taken: June 14, 2019
Digital Photo: Daniel Brooks Entrance



Development: Daniel Brooks Homes
Building Number: 1455 West Ave.
Description: Daniel Brooks Honorary Flagpole
Photographer: High Point Housing Authority
Date Taken: June 14, 2019
Digital Photo: Daniel Brooks Honorary Flagpole



Davis Ave

Henley St

Henley St

Henley St

Henley St

West Ave

Saunders Pl

Henley St

Henley St

Saunders Pl

West Ave

N Downing St

Davis Ave

Saunders Pl

N Downing St

West Ave

Moon Pl

Saunders Pl

N Downing St

N Downing St

Saunders Pl

N Downing St

N Downing St

N Downing St

West Ave

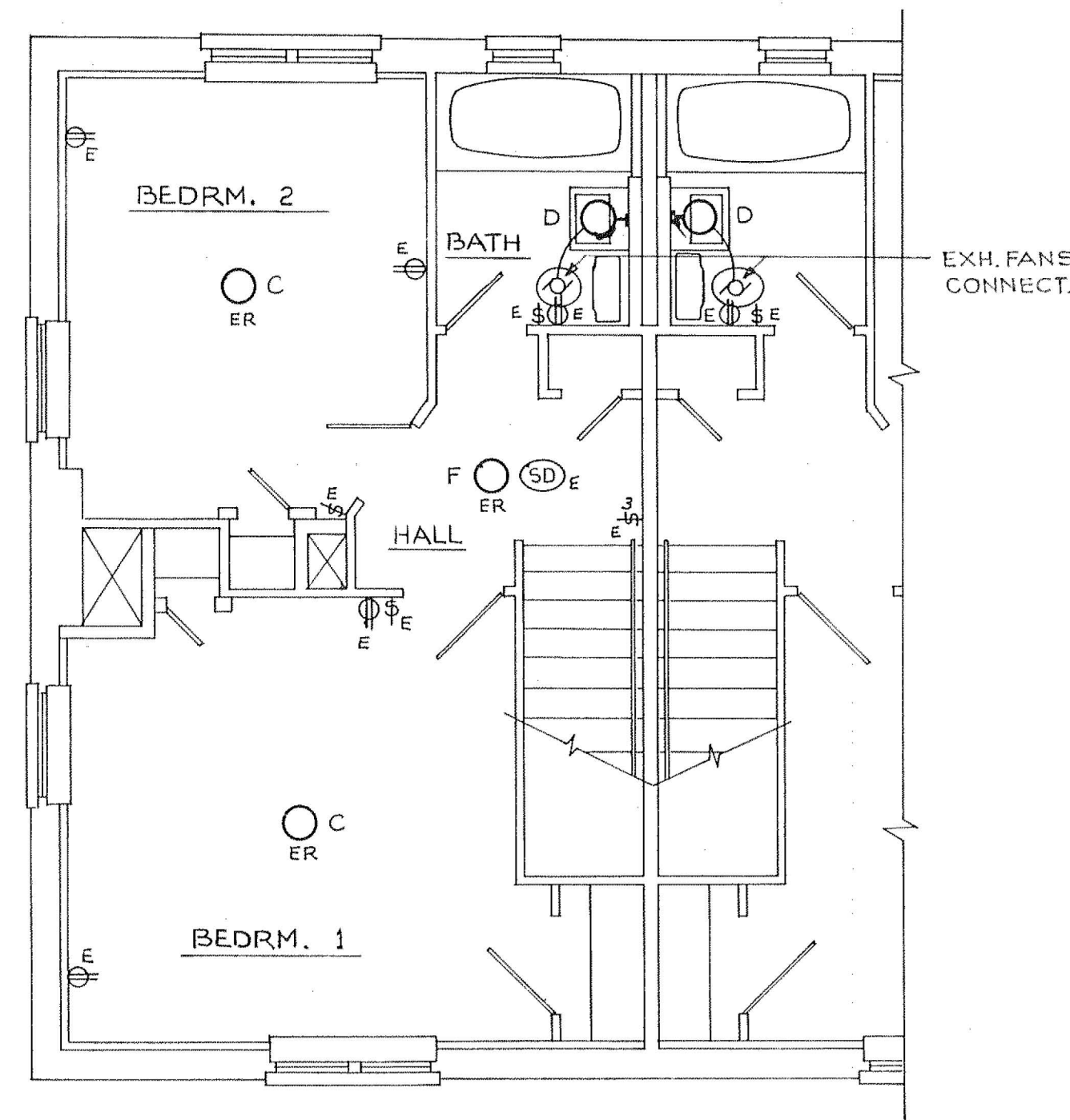

BLOG. "A" SECOND FLOOR PLAN

1/4" = 1'-0"

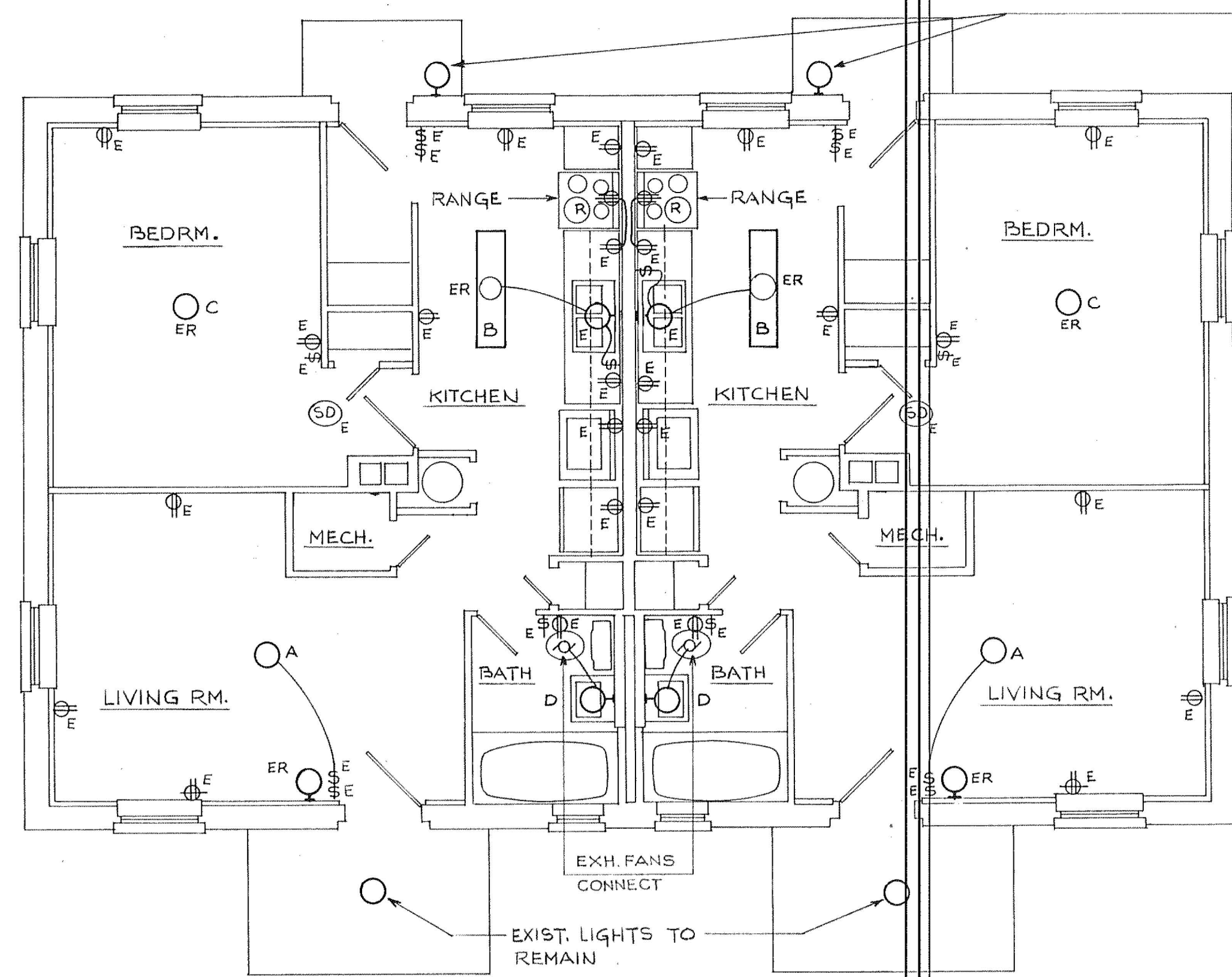

12 BLDGS. - 24 LIVING UNITS REQ'D. - SEE SH. S-1

BLOG. "B" FLOOR PLAN

1/4" = 1'-0"

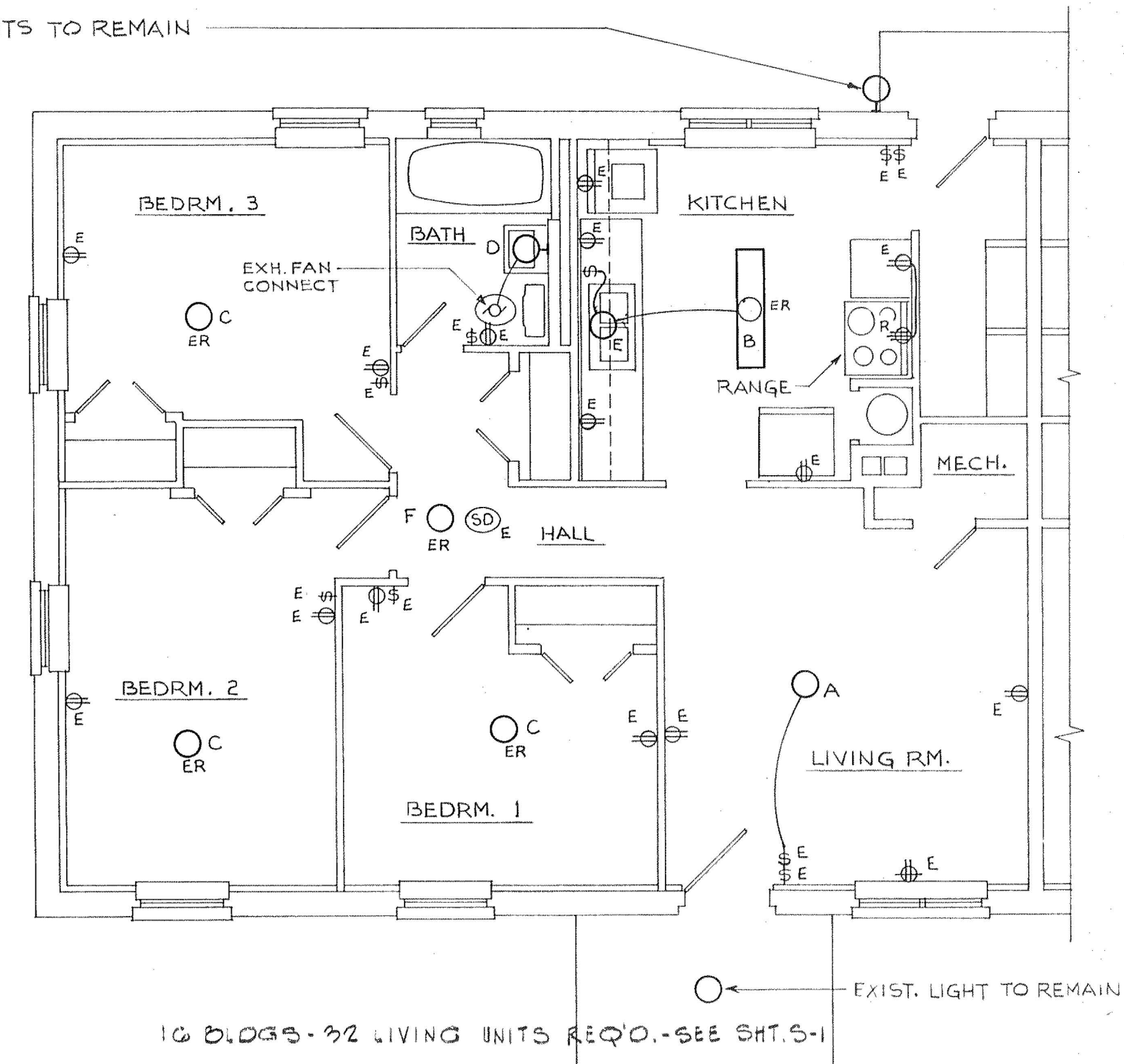

16 BLDGS. - 32 LIVING UNITS REQ'D. - SEE SH. S-1

BLOG. "C" FLOOR PLAN

1/4" = 1'-0"

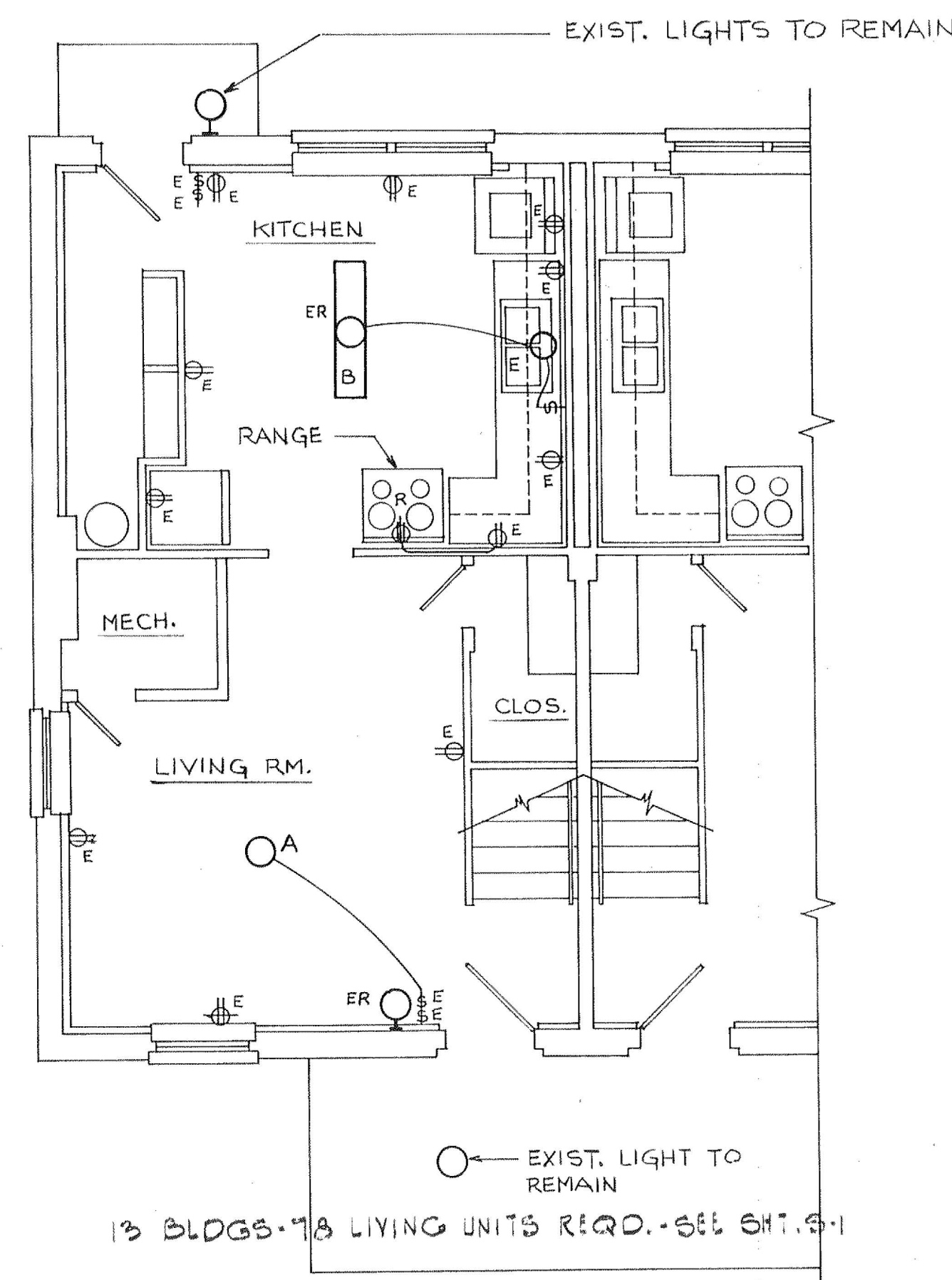

13 BLDGS. - 18 LIVING UNITS REQ'D. - SEE SH. S-1

BLOG. "A" FIRST FLOOR PLAN

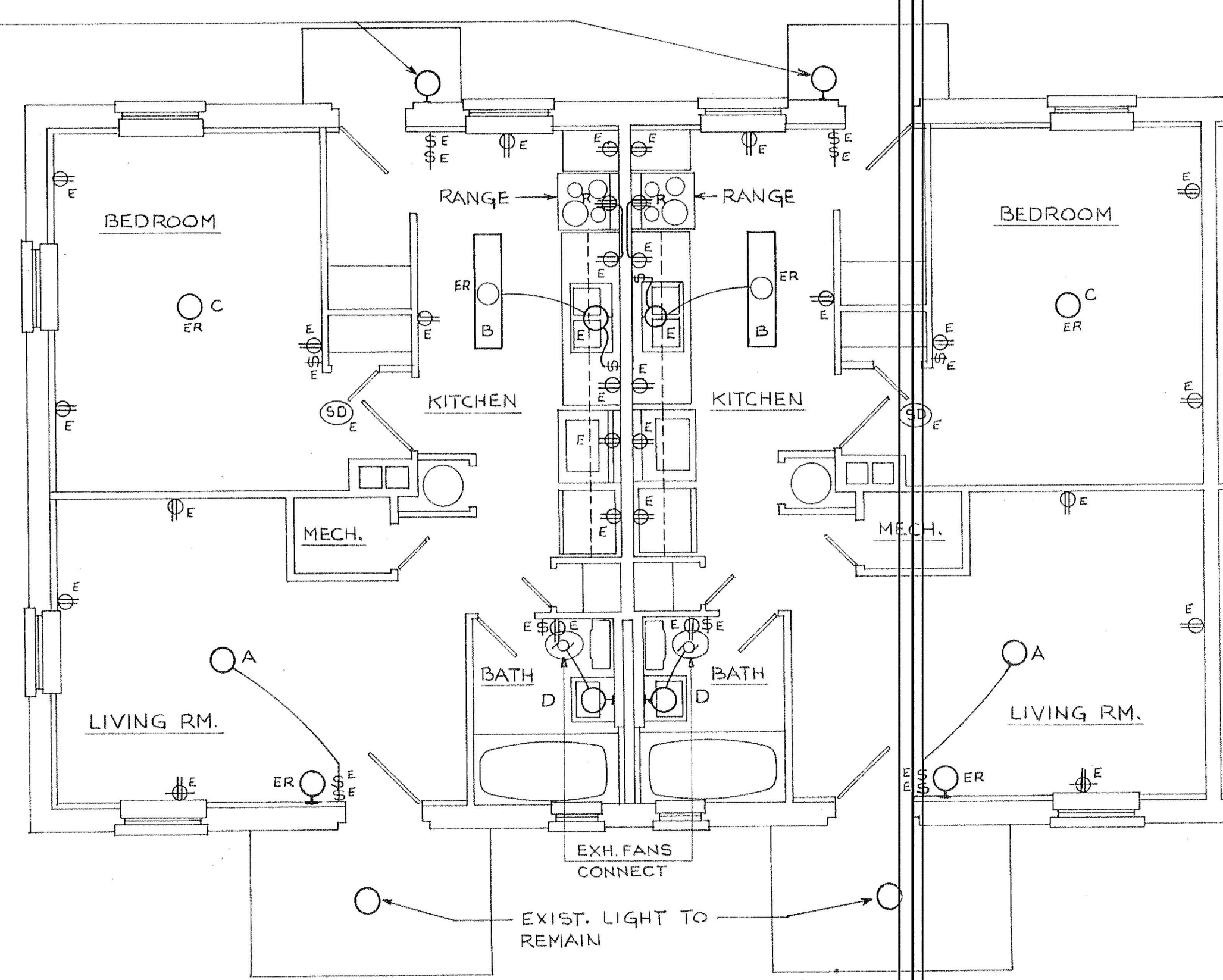

5 BLDGS. - 30 LIVING UNITS REQ'D. - SEE SH. S-1

BLOG. "D" FLOOR PLAN

1/4" = 1'-0"

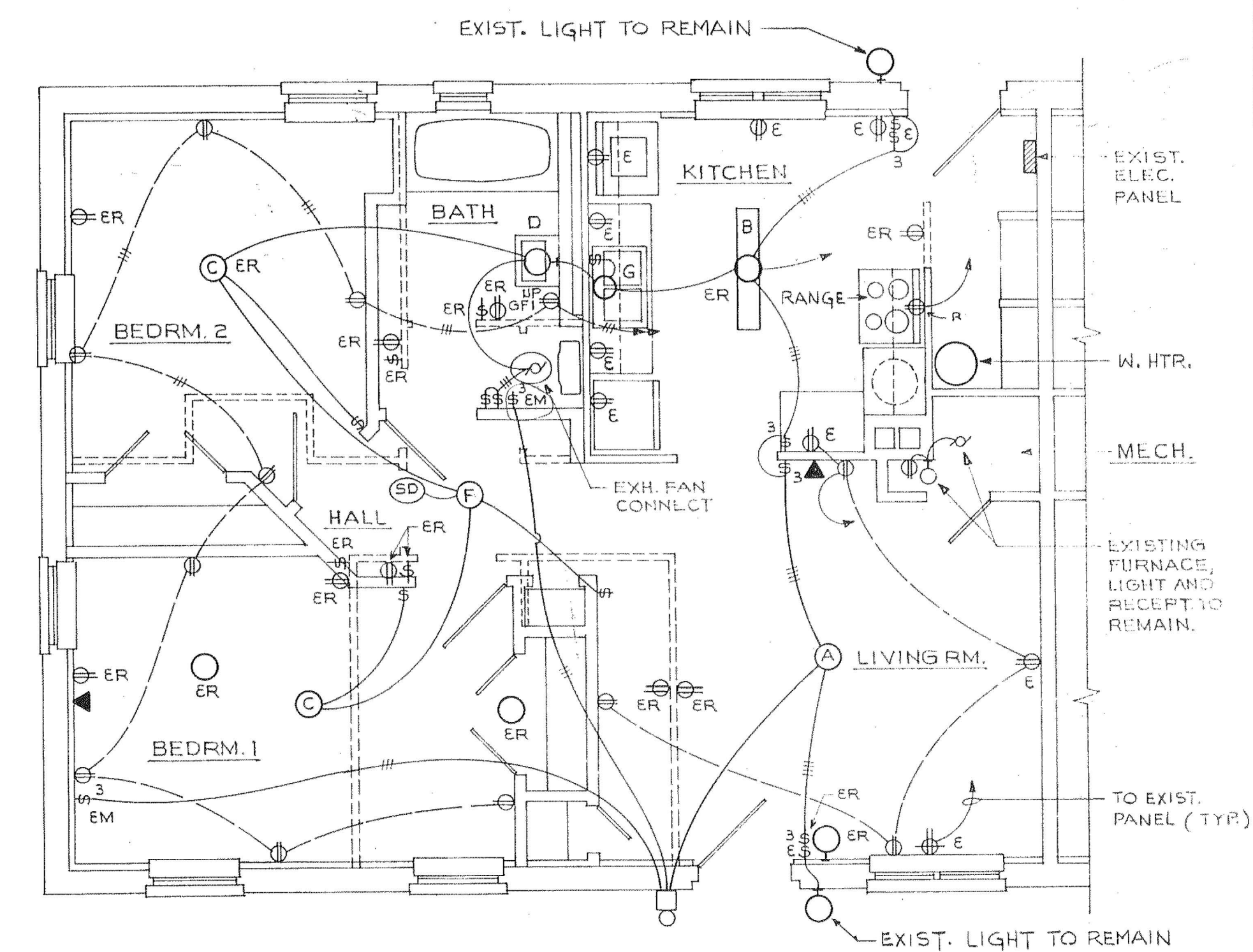

4 BLDGS. - 8 LIVING UNITS REQUIRED - SEE SH. S-1

BUILDING "H" FLOOR PLAN

1/4" = 1'-0"



Development: Daniel Brooks Homes
Building Number: 1453 West Ave.
Description: Front View Daniel Brooks Day Care
Photographer: High Point Housing Authority
Date Taken: June 14, 2019
Digital Photo: Day Care Front View

Daniel Brooks
Early Head Start Center



1453 West Ave.
886-7732

Guilford**Child**Development

Development: Daniel Brooks Homes
Building Number: 1453 West Ave.
Description: Daniel Brooks Day Care Sign
Photographer: High Point Housing Authority
Date Taken: June 14, 2019
Digital Photo: Day Care Sign



Development: Daniel Brooks Homes
Building Number: 1453 West Ave.
Description: Yard View Daniel Brooks Day Care
Photographer: High Point Housing Authority
Date Taken: June 14, 2019
Digital Photo: Day Care Yard View



Development: Daniel Brooks Homes

Building Number: 1447 West Ave.

Description: Yard View 1447 West Ave.

Photographer: High Point Housing Authority

Date Taken: June 14, 2019

Digital Photo: Green Space 1447 West Ave.



Development: Daniel Brooks Homes

Building Number: 1479 West Ave.

Description: Yard View of the 1400 Block of West Ave.

Photographer: High Point Housing Authority

Date Taken: June 14, 2019

Digital Photo: 1479 West Green Space



Development: Daniel Brooks Homes

Building Number: 1479 West Ave.

Description: Yard View of the 1400 Block of West Ave.

Photographer: High Point Housing Authority

Date Taken: June 14, 2019

Digital Photo: 1479 West Green Space



Development: Daniel Brooks Homes
Building Number: NA
Description: Intricate Stone Retainer Walls
Photographer: High Point Housing Authority
Date Taken: June 14, 2019
Digital Photo: Intricate Stone Retainer Walls 1



Development: Daniel Brooks Homes
Building Number: NA
Description: Intricate Stone Retainer Walls
Photographer: High Point Housing Authority
Date Taken: June 14, 2019
Digital Photo: Intricate Stone Retainer Walls 2



Development: Daniel Brooks Homes
Building Number: NA
Description: Intricate Stone Retainer Walls
Photographer: High Point Housing Authority
Date Taken: June 14, 2019
Digital Photo: Intricate Stone Retainer Walls 3



Development: Daniel Brooks Homes
Building Number: NA
Description: Intricate Stone Retainer Walls
Photographer: High Point Housing Authority
Date Taken: June 14, 2019
Digital Photo: Intricate Stone Retainer Walls 4

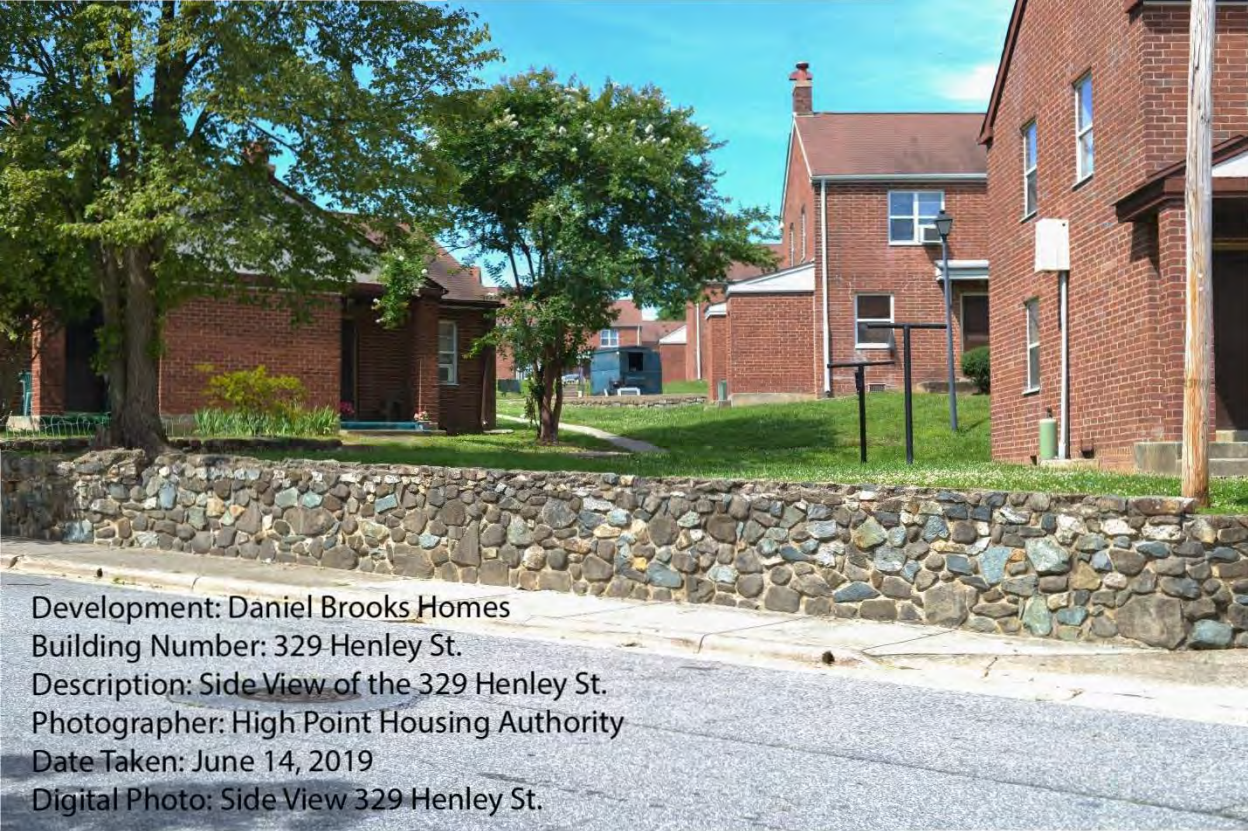

Development: Daniel Brooks Homes
Building Number: 329 Henley St.
Description: Side View of the 329 Henley St.
Photographer: High Point Housing Authority
Date Taken: June 14, 2019
Digital Photo: Side View 329 Henley St.



Development: Daniel Brooks Homes
Building Number: 327 Henley St.
Description: Street View of the 327 Henley St.
Photographer: High Point Housing Authority
Date Taken: June 14, 2019
Digital Photo: Street View 327 Henley St.



Development: Daniel Brooks Homes

Building Number: 337 Henley St.

Description: Street View of the 300 Block of Henley

Photographer: High Point Housing Authority

Date Taken: June 14, 2019

Digital Photo: Street View 337 Henley St.